



## Multi-dimensional classification with Bayesian networks

C. Bielza<sup>a</sup>, G. Li<sup>b</sup>, P. Larrañaga<sup>a,\*</sup>

<sup>a</sup> Computational Intelligence Group, Departamento de Inteligencia Artificial, Universidad Politécnica de Madrid, Boadilla del Monte, 28660 Madrid, Spain

<sup>b</sup> Rega Institute and University Hospitals, Katholieke Universiteit Leuven, B-3000 Leuven, Belgium

### ARTICLE INFO

#### Article history:

Received 30 July 2010

Revised 2 December 2010

Accepted 21 January 2011

Available online 16 February 2011

#### Keywords:

Multi-dimensional outputs

Bayesian network classifiers

Learning from data

MPE

Multi-label classification

### ABSTRACT

Multi-dimensional classification aims at finding a function that assigns a vector of class values to a given vector of features. In this paper, this problem is tackled by a general family of models, called multi-dimensional Bayesian network classifiers (MBCs). This probabilistic graphical model organizes class and feature variables as three different subgraphs: class subgraph, feature subgraph, and bridge (from class to features) subgraph. Under the standard 0–1 loss function, the most probable explanation (MPE) must be computed, for which we provide theoretical results in both general MBCs and in MBCs decomposable into maximal connected components. Moreover, when computing the MPE, the vector of class values is covered by following a special ordering (gray code). Under other loss functions defined in accordance with a decomposable structure, we derive theoretical results on how to minimize the expected loss. Besides these inference issues, the paper presents flexible algorithms for learning MBC structures from data based on filter, wrapper and hybrid approaches. The cardinality of the search space is also given. New performance evaluation metrics adapted from the single-class setting are introduced. Experimental results with three benchmark data sets are encouraging, and they outperform state-of-the-art algorithms for multi-label classification.

© 2011 Elsevier Inc. All rights reserved.

## 1. Introduction

In this paper we are interested in classification problems where there are multiple class variables  $C_1, \dots, C_d$ . Therefore the *multi-dimensional classification* problem consists of finding a function  $h$  that assigns to each instance given by a vector of  $m$  features  $\mathbf{x} = (x_1, \dots, x_m)$  a vector of  $d$  class values  $\mathbf{c} = (c_1, \dots, c_d)$ :

$$h : \Omega_{X_1} \times \dots \times \Omega_{X_m} \rightarrow \Omega_{C_1} \times \dots \times \Omega_{C_d}$$

$$(x_1, \dots, x_m) \mapsto (c_1, \dots, c_d)$$

We assume that  $C_i$  is a discrete variable, for all  $i = 1, \dots, d$ , with  $\Omega_{C_i}$  denoting its sample space and  $\mathcal{I} = \Omega_{C_1} \times \dots \times \Omega_{C_d}$ , the space of joint configurations of the class variables. Analogously,  $\Omega_{X_j}$  is the sample space of the discrete feature variable  $X_j$ , for all  $j = 1, \dots, m$ .

\* Corresponding author. Tel.: +34 91 3367443; fax: +34 91 3524819.

E-mail addresses: [mcbielza@fi.upm.es](mailto:mcbielza@fi.upm.es) (C. Bielza), [guangdi.li@rega.kuleuven.be](mailto:guangdi.li@rega.kuleuven.be) (G. Li), [pedro.larranaga@fi.upm.es](mailto:pedro.larranaga@fi.upm.es) (P. Larrañaga).

Many application domains include multi-dimensional classification problems: a text document or a semantic scene can be assigned to multiple topics, a gene can have multiple biological functions, a patient may suffer from multiple diseases, a patient may become resistant to multiple drugs for HIV treatment, a physical device can break down due to multiple components failing, etc.

Multi-dimensional classification is a more difficult problem than the single-class case. The main problem is that there is a large number of possible class label combinations,  $|I|$ , and a corresponding sparseness of available data. In a typical scenario where an instance  $\mathbf{x}$  is assigned to the most likely combination of classes (0–1 loss function), the aim is to compute  $\arg \max_{c_1, \dots, c_d} p(C_1 = c_1, \dots, C_d = c_d | \mathbf{x})$ . It holds that  $p(C_1 = c_1, \dots, C_d = c_d | \mathbf{x}) \propto p(C_1 = c_1, \dots, C_d = c_d, \mathbf{x})$ , which requires  $|I| \cdot |\Omega_{X_1}| \times \dots \times |\Omega_{X_m}|$  parameters to be assigned. In the single-class case,  $|I|$  is just  $|\Omega_C|$  rather than  $|\Omega_{C_1}| \times \dots \times |\Omega_{C_d}|$ . Besides it having a high cardinality, it is also hard to estimate the required parameters from a (sparse) data set in this  $d$ -dimensional space  $|I|$ . The factorization of this joint probability distribution when using a Bayesian network (BN) can somehow reduce the number of parameters required and will be our starting point.

Standard (one-class) BN classifiers cannot be straightforwardly applied to this multi-dimensional setting. On the one hand, the problem could be transformed into a single-class problem if a compound class variable modeling all possible combinations of classes is constructed. However, this class variable would have too many values, and even worse, the model would not capture the structure of the classification problem (dependencies among class variables and also among class variables and features). On the other hand, we could approach the multi-dimensional problem by constructing one independent classifier for each class variable. However, this would not capture the interactions among class variables, and the most likely class label for each independent classifier – marginal classifications – after being assembled as a  $d$ -dimensional vector, might not coincide with the most likely vector of class labels of the observed data.

As we will show below, the few proposals found in the literature on multi-dimensional BN classifiers (MBCs) are limited. In this paper, we propose a comprehensive theory of MBCs, including their extended definition, learning from data algorithms that cover all the possibilities (wrapper, filter and hybrid score + search strategies), and results on how to perform total abduction for the exact inference of the most probable explanation (MPE). MPE computation is the main aim in 0–1 loss function classification problems but involves a high computational cost in the multi-dimensional setting. Several contributions are designed here to reduce this computational load: the introduction of special decomposed MBCs, their extension to non 0–1 loss function problems that respect this decomposition, and a particular and favorable way of enumerating all the  $(c_1, \dots, c_d)$  configurations instead of using a brute-force approach.

The paper is organized as follows: Section 2 defines MBCs. Section 3 covers different contributions for the MPE computation and introduces a restricted structure of decomposable MBCs where MPE is easier to compute. Section 4 extends these ideas to compute the Bayes decision rule with certain loss functions that we call additive CB-decomposable loss functions. Section 5 presents performance measures suitable for evaluating MBCs. Section 6 describes wrapper, filter and hybrid algorithms to learn MBCs from data. It also provides the cardinality of the MBC structure space where these algorithms search for. Section 7 shows experimental results on MPE with simulated MBCs. Section 8 contains experimental results with three benchmark data sets. Section 9 reviews the work related to multi-dimensional classification, with special emphasis on papers using (simpler) MBCs. Finally, Section 10 sums up the paper with some conclusions.

## 2. Multi-dimensional Bayesian network classifiers

A Bayesian network over a finite set  $\mathcal{V} = \{Z_1, \dots, Z_n\}$ ,  $n \geq 1$ , of discrete random variables is a pair  $B = (\mathcal{G}, \Theta)$ , where  $\mathcal{G}$  is an acyclic directed graph whose vertices correspond to the random variables and  $\Theta$  is a set of parameters  $\theta_{z|\mathbf{pa}(z)} = p(z|\mathbf{pa}(z))$ , where  $\mathbf{pa}(z)$  is a value of the set of variables  $\mathbf{Pa}(Z)$ , parents of the  $Z$  variable in the graphical structure  $\mathcal{G}$  [42,36].  $B$  defines a joint probability distribution  $p_B$  over  $\mathcal{V}$  given by

$$p_B(z_1, \dots, z_n) = \prod_{i=1}^n p(z_i | \mathbf{pa}(z_i)). \quad (1)$$

A *multi-dimensional Bayesian network classifier* is a Bayesian network specially designed to solve classification problems including multiple class variables in which instances described by a number of features have to be assigned to a combination of classes.

**Definition 1** (*Multi-dimensional Bayesian network classifier*). In an MBC denoted by  $B = (\mathcal{G}, \Theta)$ , the graph  $\mathcal{G} = (\mathcal{V}, \mathcal{A})$  has the set  $\mathcal{V}$  of vertices partitioned into two sets  $\mathcal{V}_C = \{C_1, \dots, C_d\}$ ,  $d \geq 1$ , of class variables and  $\mathcal{V}_X = \{X_1, \dots, X_m\}$ ,  $m \geq 1$ , of feature variables ( $d + m = n$ ).  $\mathcal{G}$  also has the set  $\mathcal{A}$  of arcs partitioned into three sets,  $\mathcal{A}_C, \mathcal{A}_X, \mathcal{A}_{CX}$ , such that:

- $\mathcal{A}_C \subseteq \mathcal{V}_C \times \mathcal{V}_C$  is composed of the arcs between the class variables having a subgraph  $\mathcal{G}_C = (\mathcal{V}_C, \mathcal{A}_C)$  –class subgraph– of  $\mathcal{G}$  induced by  $\mathcal{V}_C$ .
- $\mathcal{A}_X \subseteq \mathcal{V}_X \times \mathcal{V}_X$  is composed of the arcs between the feature variables having a subgraph  $\mathcal{G}_X = (\mathcal{V}_X, \mathcal{A}_X)$  –feature subgraph– of  $\mathcal{G}$  induced by  $\mathcal{V}_X$ .

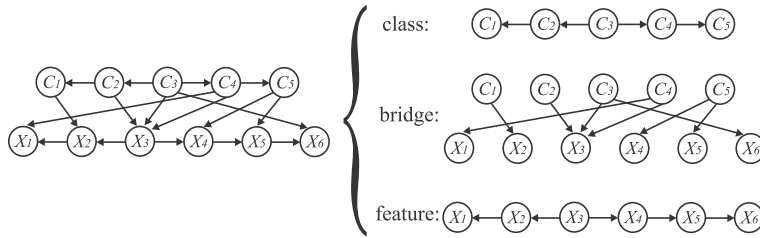

Fig. 1. An example of an MBC structure with its three subgraphs.

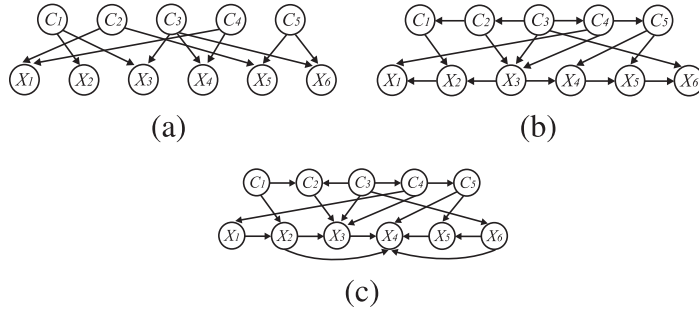

Fig. 2. Examples of structures belonging to different families of MBCs. (a) Empty-empty MBC; (b) Tree-tree MBC; (c) Polytree-DAG MBC.

- $\mathcal{A}_{c\mathcal{X}} \subseteq \mathcal{V}_c \times \mathcal{V}_\mathcal{X}$  is composed of the arcs from the class variables to the feature variables having a subgraph  $\mathcal{G}_{c\mathcal{X}} = (\mathcal{V}, \mathcal{A}_{c\mathcal{X}})$  –bridge subgraph– of  $\mathcal{G}$  connecting class and feature variables.

This definition extends that in van der Gaag and de Waal [70], which requires two additional conditions (see Section 6.4). Fig. 1 shows an example of an MBC structure and its different subgraphs.

Note that different graphical structures for the class and feature subgraphs may give rise to different families of MBCs. In general, class and feature subgraphs may be: empty, directed trees, forest of trees, polytrees, and general directed acyclic graphs (DAG). The different families of MBCs will be denoted as *class subgraph structure*–*feature subgraph structure* MBC, where the possible structures are the above five. Thus, if both the class and feature subgraphs are directed trees, then this subfamily is a *tree-tree* MBC. Other examples are shown in Fig. 2.

Note that the well-known Bayesian classifiers: naïve Bayes [40], selective naïve Bayes [37], tree-augmented naïve Bayes [24], selective tree-augmented naïve Bayes [3] and  $k$ -dependence Bayesian classifiers [53] are special cases of MBCs where  $d = 1$ . Several MBC structures have been used in the literature: *tree-tree* MBC [70], *polytree-polytree* MBC [15] and a special *DAG-DAG* MBC [51].

The following theorem extends the well-known result that states that given a 0–1 loss function in a (one-dimensional) classification problem, the Bayes decision rule is to select the class label that maximizes the posterior probability of the class variable given the features. This supports the use of the percentage of correctly classified instances (or classifier accuracy) as a performance measure. In Section 5 we extend the definition of accuracy to our multi-dimensional setting.

**Theorem 1.** Let  $\lambda(\mathbf{c}', \mathbf{c})$  be a 0–1 loss function that assigns a unit loss to any error, i.e. whenever  $\mathbf{c}' \neq \mathbf{c}$ , where  $\mathbf{c}'$  is the  $d$ -dimensional vector of class values output by a model and  $\mathbf{c}$  contains the true class value and assigns no loss to a correct classification, i.e. when  $\mathbf{c}' = \mathbf{c}$ .

Let  $R(\mathbf{c}'|\mathbf{x}) = \sum_{j=1}^{|\mathcal{I}|} \lambda(\mathbf{c}', \mathbf{c}_j)p(\mathbf{c}_j|\mathbf{x})$  be the expected loss or conditional risk, where  $\mathbf{x} = (x_1, \dots, x_m)$  is a vector of feature values and  $p(\mathbf{c}_j|\mathbf{x})$  is the joint posterior probability, provided by a model, of the vector of the class value  $\mathbf{c}_j$  given the observation  $\mathbf{x}$ .

Then the Bayes decision rule that minimizes the expected loss  $R(\mathbf{c}'|\mathbf{x})$  is equivalent to selecting the  $\mathbf{c}'$  that maximizes the posterior probability  $p(\mathbf{c}'|\mathbf{x})$ , that is,

$$\min_{\mathbf{c}'} R(\mathbf{c}'|\mathbf{x}) \Leftrightarrow \max_{\mathbf{c}'} p(\mathbf{c}'|\mathbf{x})$$

**Proof.** The proof is straightforward and analogous to the single-class variable case [22] using  $\mathbf{C} = (C_1, \dots, C_d)$  as the ( $d$ -dimensional) class variable, i.e.

$$R(\mathbf{c}'|\mathbf{x}) = \sum_{j=1}^{|\mathcal{I}|} \lambda(\mathbf{c}', \mathbf{c}_j)p(\mathbf{c}_j|\mathbf{x}) = \sum_{\mathbf{c}_j \neq \mathbf{c}'} p(\mathbf{c}_j|\mathbf{x}) = 1 - p(\mathbf{c}'|\mathbf{x}). \quad \square$$

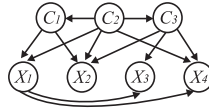

Fig. 3. An example of MBC structure.

Therefore, the multi-dimensional classification problem with a 0–1 loss is equivalent to computing a type of maximum a posteriori (MAP), known as *most probable explanation* (MPE), also called total abduction [42]. This has been shown to be a NP-hard problem for Bayesian networks [56]. Approximating the MPE problem is also NP-hard [1].

However, the special structure that defines the MBC will alleviate somewhat MPE computation under certain circumstances, as shown in the next section.

### 3. Theoretical results on MPE

The NP-hardness of MPE computation in general Bayesian networks has led to the design of both exact and approximate algorithms. Exact algorithms include approaches using junction trees [13], variable elimination [38,17], and branch-and-bound search [34,39]. Approximate algorithms cover the use of genetic algorithms [26,52], stochastic local search algorithms [33,31], the so-called mini-bucket approach based on variable elimination [18], best-first search [57] and linear programming [54].

MPE computation when having  $d$  class variables increases the number of possible configurations exponentially, i.e. given evidence  $\mathbf{x}$  we have to get

$$\mathbf{c}^* = (c_1^*, \dots, c_d^*) = \arg \max_{c_1, \dots, c_d} p(C_1 = c_1, \dots, C_d = c_d | \mathbf{x}). \tag{2}$$

De Waal and van der Gaag (2007) show that the classification problem can be solved in polynomial time if the feature subgraph has bounded treewidth and the number of class variables is restricted (see their Theorem 1). This implies that the connectivity of the class subgraph is irrelevant for the feasibility of classification.

This section reports two major contributions. On the one hand, thanks to the specific structure of MBCs and a special way (gray code) of moving within the  $\mathcal{I}$  space of joint configurations of the class variables, we will be able, despite this high complexity, to reduce the computations performed to obtain the posterior probability  $p(C_1 = c_1, \dots, C_d = c_d | \mathbf{x})$  and finally get the MPE. This will be feasible for a small number  $d$  of classes, since gray codes are helpful for exhaustively enumerating the  $\mathcal{I}$  space. An upper bound for the savings achieved with respect to a brute-force approach is also provided. On the other hand, when the graph union of class and bridge subgraphs of an MBC structure is decomposed into a number,  $r$ , of connected subgraphs, we prove that the maximization problem for computing the MPE can be transformed into  $r$  maximization problems operating in lower dimensional spaces. These simpler structures will be called class-bridge decomposable MBCs. Analogous results with gray codes in this case are also presented.

The main motivation for trying to enumerate the  $\mathcal{I}$  space lies in the similarity between the posterior probability of two configurations that have the same class values in all components but one. This is shown in Example 1.

**Example 1.** Given the MBC structure of Fig. 3, where all variables are assumed to be binary (0/1) and  $\mathbf{x} = (x_1, x_2, x_3, x_4)$ , the posterior probabilities of configurations (0, 0, 0) and (1, 0, 0) for  $(C_1, C_2, C_3)$  satisfy:

$$\begin{aligned} \frac{p((0, 0, 0) | \mathbf{x})}{p((1, 0, 0) | \mathbf{x})} &= \frac{p(0, 0, 0, \mathbf{x})}{p(1, 0, 0, \mathbf{x})} \\ &= \frac{p(C_1 = 0 | C_2 = 0) p(C_2 = 0) p(C_3 = 0 | C_2 = 0) p(X_1 = x_1 | C_1 = 0, C_2 = 0)}{p(C_1 = 1 | C_2 = 0) p(C_2 = 0) p(C_3 = 0 | C_2 = 0) p(X_1 = x_1 | C_1 = 1, C_2 = 0)} \\ &\quad \cdot \frac{p(X_2 = x_2 | C_1 = 0, C_2 = 0, C_3 = 0) p(X_3 = x_3 | C_3 = 0, X_1 = x_1)}{p(X_2 = x_2 | C_1 = 1, C_2 = 0, C_3 = 0) p(X_3 = x_3 | C_3 = 0, X_1 = x_1)} \\ &\quad \cdot \frac{p(X_4 = x_4 | C_2 = 0, C_3 = 0, X_1 = x_1)}{p(X_4 = x_4 | C_2 = 0, C_3 = 0, X_1 = x_1)} \\ &= \frac{p(C_1 = 0 | C_2 = 0) p(X_1 = x_1 | C_1 = 0, C_2 = 0) p(X_2 = x_2 | C_1 = 0, C_2 = 0, C_3 = 0)}{p(C_1 = 1 | C_2 = 0) p(X_1 = x_1 | C_1 = 1, C_2 = 0) p(X_2 = x_2 | C_1 = 1, C_2 = 0, C_3 = 0)} \end{aligned}$$

This may be generalized in the following proposition.

$C_1$	$C_2$	$C_3$
0	0	0
1	0	0
2	0	0
2	1	0
1	1	0
0	1	0
0	2	0
1	2	0
2	2	0
2	2	1
1	2	1
0	2	1
0	1	1
1	1	1
2	1	1
2	0	1
1	0	1
0	0	1

Fig. 4. (3, 3, 2; 3)-gray code.

**Proposition 1.** Given an MBC and an instantiation of all the feature variables  $\mathbf{x} = (x_1, \dots, x_m)$ , then the ratio of posterior distributions of two  $d$ -dimensional class configurations  $\mathbf{c} = (c_1, \dots, c_d)$  and  $\mathbf{c}' = (c'_1, \dots, c'_d)$  is given by

$$\frac{p(\mathbf{c}|\mathbf{x})}{p(\mathbf{c}'|\mathbf{x})} = \frac{\prod_{C_i \in \mathcal{W}} p(C_i = c_i | \mathbf{pa}(c_i))}{\prod_{C_i \in \mathcal{W}} p(C_i = c'_i | \mathbf{pa}(c'_i))} \cdot \frac{\prod_{X_j \in \text{Ch}(\mathcal{W})} p(X_j = x_j | \mathbf{pa}(x_j))}{\prod_{X_j \in \text{Ch}(\mathcal{W})} p(X_j = x_j | \mathbf{pa}'(x_j))},$$

where  $\mathcal{W} = \{C_i \in \mathcal{V}_C \mid \exists ! l \in \{1, \dots, d\}, c_l \neq c'_l\}$ ,  $\mathbf{pa}'(x_j)$  denotes the configuration of  $\mathbf{Pa}(X_j)$  compatible with  $\mathbf{x}$  and  $\mathbf{c}'$ , and  $\text{Ch}(\mathcal{W})$  denotes the feature variables that are children of variables in set  $\mathcal{W}$ .

**Proof.** In the numerator,

$$p(\mathbf{c}|\mathbf{x}) = \frac{1}{p(\mathbf{x})} \prod_{C_i \in \mathcal{W}} p(C_i = c_i | \mathbf{pa}(c_i)) \prod_{C_i \notin \mathcal{W}} p(C_i = c_i | \mathbf{pa}(c_i)) \prod_{X_j \in \text{Ch}(\mathcal{W})} p(X_j = x_j | \mathbf{pa}(x_j)) \prod_{X_j \notin \text{Ch}(\mathcal{W})} p(X_j = x_j | \mathbf{pa}(x_j))$$

In the denominator, the factorization for  $p(\mathbf{c}'|\mathbf{x})$  is analogous and its first, third, and fifth factors coincide with those in  $p(\mathbf{c}|\mathbf{x})$ . This leads directly to the final result.  $\square$

**Corollary 1.** In the above situation, where  $\mathbf{c}$  and  $\mathbf{c}'$  now differ by only one component  $l$ , i.e.  $c_i = c'_i \forall i \neq l$  and  $c_l \neq c'_l$ , then

$$\frac{p(\mathbf{c}|\mathbf{x})}{p(\mathbf{c}'|\mathbf{x})} = \frac{p(C_l = c_l | \mathbf{pa}(c_l))}{p(C_l = c'_l | \mathbf{pa}(c'_l))} \cdot \frac{\prod_{X_j \in \text{Ch}(C_l)} p(X_j = x_j | \mathbf{pa}(x_j))}{\prod_{X_j \in \text{Ch}(C_l)} p(X_j = x_j | \mathbf{pa}'(x_j))}.$$

These configurations  $\mathbf{c}$  and  $\mathbf{c}'$  differing by one component (as in Example 1) provide more savings than in the general case of Proposition 1. For simplicity's sake, we can choose  $c_l$  and  $c'_l$  such that  $|c_l - c'_l| = 1$ . In this case, an adaptation of the gray code introduced by Guan [28] is proposed for enumerating all the  $(c_1, \dots, c_d)$  configurations in a special order. Guan's  $(n; k)$ -gray code is a special sequence enumerating all elements in  $(\mathbb{Z}_n)^k$ , that is, vectors of  $k$  components each taking values in the space  $\{0, 1, \dots, n - 1\}$ . Therefore, components are restricted to being in the same range. We, however, extend gray codes to different ranges  $r_i, i = 1, \dots, d$ , having  $(r_1, \dots, r_d; d)$ -gray codes.

**Definition 2** ( $(r_1, \dots, r_d; d)$ -gray code). Given a vector  $(C_1, \dots, C_d)$  with each component  $C_i$  taking values in  $\{0, 1, \dots, r_i - 1\}, i = 1, \dots, d$ , an  $(r_1, \dots, r_d; d)$ -gray code is a sequence that enumerates all the configurations  $(c_1, \dots, c_d)$  such that each pair of adjacent configurations differs by only one component and the difference is either 1 or  $-1$ .

**Example 2.** Fig. 4 shows the sequence of configurations for a (3, 3, 2; 3)-gray code, i.e. triplets where the first component takes values in  $\{0, 1, 2\}$ , the second in  $\{0, 1, 2\}$  and the third in  $\{0, 1\}$ .

In this example, if  $S_i$  denotes the number of changes in the  $i$ th component to cover the whole gray code, then  $S_3 = 1, S_2 = 4, S_1 = 12$  (see the boxes in Fig. 4).

The general formula for  $S_i$  follows.

**Proposition 2.** In the  $(r_1, \dots, r_d; d)$ -gray code, the number of changes,  $S_i$ , in the  $i$ th component, is given by

$$S_i = \begin{cases} \prod_{j=i}^d r_j - \prod_{j=i+1}^d r_j, & 1 \leq i \leq d-1 \\ r_d - 1, & i = d \end{cases}$$

Moreover,  $\sum_{i=1}^d S_i = \prod_{j=1}^d r_j - 1$ .

**Proof.** For  $i = d$ ,  $S_d = r_d - 1$  since the last component is the one is moved least by gray coding. For  $1 \leq i \leq d-1$ ,  $S_i = r_d \cdot r_{d-1} \cdots r_{i+1} \cdot (r_i - 1)$ , since the  $i$ th component has  $r_i - 1$  changes for each partial configuration of fixed values in components  $i+1, \dots, d$ , which are  $r_d \cdot r_{d-1} \cdots r_{i+1}$ .

Also,

$$\begin{aligned} \sum_{i=1}^d S_i &= \sum_{i=1}^{d-1} \left( \prod_{j=i}^d r_j - \prod_{j=i+1}^d r_j \right) + r_d - 1 = (r_1 \cdots r_d) - (r_2 \cdots r_d) + (r_2 \cdots r_d) - (r_3 \cdots r_d) \\ &\quad + \cdots + (r_{d-1} \cdots r_d) - r_d + r_d - 1 = r_1 \cdots r_d - 1. \quad \square \end{aligned}$$

Computations to obtain MPE in MBCs are reduced by using these gray codes. The next theorem shows the savings and an upper bound when comparing the number of factors needed in the posterior probability computations with gray codes,  $F_{GC}$ , and with brute-force,  $F_{BF}$ .

**Theorem 2.** Given an MBC with  $m$  feature variables and  $d$  class variables, where  $\mathcal{I}$  is the space of joint configurations of the class variables, then the number of factors needed in the posterior probability computations with gray codes,  $F_{GC}$ , and with brute-force,  $F_{BF}$ , satisfy:

- (i)  $F_{GC} = m + d + \sum_{i=1}^d S_i H_i$
- (ii)  $\frac{F_{GC}}{F_{BF}} < \frac{1}{|\mathcal{I}|} + \frac{H_{Max}}{m+d}$ ,

where  $H_i = 1 + h_i$ ,  $h_i$  being the number of children (in the MBC) of the class variable that changes the  $i$ th in the gray code, and  $H_{Max} = \max_{1 \leq i \leq d} H_i$ .

**Proof.** (i)  $F_{GC} = m + d + \sum_{i=1}^d S_i H_i$ , since  $m + d$  corresponds to the number of factors (without savings) for calculating the posterior probability for the first configuration where the gray code starts from, and, using Corollary 1, each configuration that changes its  $i$ th class variable in the gray code requires  $1 + h_i = H_i$  new factors. Taking into account that the number of changes in the  $i$ th class variable along the gray code sequence is  $S_i$ , the second term,  $\sum_{i=1}^d S_i H_i$ , gives the total number of factors required by all the configurations except the first one.

(ii) Obviously,  $F_{BF} = (m + d)|\mathcal{I}|$ . Also,

$$F_{GC} = m + d + \sum_{i=1}^d S_i H_i \leq m + d + H_{Max} \sum_{i=1}^d S_i = m + d + H_{Max}(|\mathcal{I}| - 1),$$

since  $\sum_{i=1}^d S_i = |\mathcal{I}| - 1$  is the total number of changes in the gray code. Therefore,

$$\frac{F_{GC}}{F_{BF}} \leq \frac{m + d + H_{Max}(|\mathcal{I}| - 1)}{(m + d)|\mathcal{I}|} < \frac{1}{|\mathcal{I}|} + \frac{H_{Max}}{m + d}. \quad \square$$

**Example 1 (continued).** Given the MBC structure of Fig. 3, where variables  $C_1$  and  $C_2$  now take three possible values and  $C_3$  is still binary, we have that  $d = 3$ ,  $m = 4$ ,  $H_{Max} = 4$ ,  $|\mathcal{I}| = 18$ .

Thus,

$$\frac{F_{GC}}{F_{BF}} = \frac{63}{126},$$

and the upper bound is  $\frac{F_{GC}}{F_{BF}} < \frac{79}{126}$ .

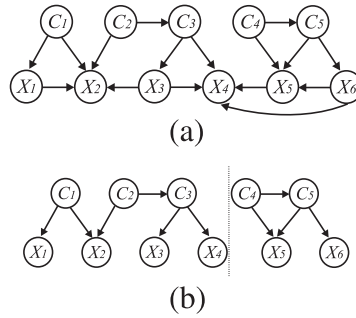

Fig. 5. (a) A CB-decomposable MBC. (b) Its two maximal connected components.

Therefore, with gray codes the number of factors is reduced by half (63 against 126), while the upper bound is a little bit higher.

**Definition 3** (CB-decomposable MBC). Suppose we have an MBC where  $\mathcal{G}_C$  and  $\mathcal{G}_{C\mathcal{X}}$  are its associated class and bridge subgraphs respectively. We say that the MBC is *class-bridge decomposable* (CB-decomposable for short) if:

- (1)  $\mathcal{G}_C \cup \mathcal{G}_{C\mathcal{X}}$  can be decomposed as  $\mathcal{G}_C \cup \mathcal{G}_{C\mathcal{X}} = \bigcup_{i=1}^r (\mathcal{G}_{C_i} \cup \mathcal{G}_{(C\mathcal{X})_i})$ , where  $\mathcal{G}_{C_i} \cup \mathcal{G}_{(C\mathcal{X})_i}$ , with  $i = 1, \dots, r$ , are its  $r$  maximal connected components,<sup>1</sup> and
- (2)  $Ch(\mathcal{V}_{C_i}) \cap Ch(\mathcal{V}_{C_j}) = \emptyset$ , with  $i, j = 1, \dots, r$  and  $i \neq j$ , where  $Ch(\mathcal{V}_{C_i})$  denotes the children of all the variables in  $\mathcal{V}_{C_i}$ , the subset of class variables in  $\mathcal{G}_{C_i}$  (*non-shared children property*).

**Example 3.** Let us take the MBC structure shown in Fig. 5(a). It is CB-decomposable with  $r = 2$ , as shown in Fig. 5(b). The subgraph to the left of the dashed vertical line is  $\mathcal{G}_{C_1} \cup \mathcal{G}_{(C\mathcal{X})_1}$ , i.e. the first maximal connected component. Analogously,  $\mathcal{G}_{C_2} \cup \mathcal{G}_{(C\mathcal{X})_2}$  to the right-hand side is the second maximal connected component. That is,  $\mathcal{V}_{C_1} = \{C_1, C_2, C_3\}$ ,  $\mathcal{V}_{C_2} = \{C_4, C_5\}$ ,  $Ch(\mathcal{V}_{C_1}) = \{X_1, X_2, X_3, X_4\}$  and  $Ch(\mathcal{V}_{C_2}) = \{X_5, X_6\}$ . Note that  $Ch(\{C_1, C_2, C_3\}) \cap Ch(\{C_4, C_5\}) = \emptyset$  as required.

**Theorem 3.** Given a CB-decomposable MBC where  $\mathcal{I}_i = \prod_{C \in \mathcal{V}_{C_i}} \Omega_C$  represents the sample space associated with  $\mathcal{V}_{C_i}$ , then

$$\begin{aligned} & \max_{c_1, \dots, c_d} p(C_1 = c_1, \dots, C_d = c_d | X_1 = x_1, \dots, X_m = x_m) \\ & \propto \prod_{i=1}^r \max_{\mathbf{c}^{\downarrow \mathcal{V}_{C_i}} \in \mathcal{I}_i} \prod_{C \in \mathcal{V}_{C_i}} p(c | \mathbf{pa}(c)) \prod_{X \in Ch(\mathcal{V}_{C_i})} p(x | \mathbf{pa}_{\mathcal{V}_C}(x), \mathbf{pa}_{\mathcal{V}_X}(x)), \end{aligned} \quad (3)$$

where  $\mathbf{c}^{\downarrow \mathcal{V}_{C_i}}$  represents the projection of vector  $\mathbf{c}$  to the coordinates found in  $\mathcal{V}_{C_i}$ .

**Proof.** By using firstly the factorization given in (1) and then the grouping of all the variables according to the CB-decomposable MBC assumption, we have that

$$\begin{aligned} & p(C_1 = c_1, \dots, C_d = c_d | X_1 = x_1, \dots, X_m = x_m) \\ & \propto \prod_{C \in \mathcal{V}_C} p(c | \mathbf{pa}(c)) \prod_{X \in \mathcal{V}_X} p(x | \mathbf{pa}_{\mathcal{V}_C}(x), \mathbf{pa}_{\mathcal{V}_X}(x)) \\ & = \prod_{i=1}^r \prod_{C \in \mathcal{V}_{C_i}} p(c | \mathbf{pa}(c)) \prod_{X \in Ch(\mathcal{V}_{C_i})} p(x | \mathbf{pa}_{\mathcal{V}_C}(x), \mathbf{pa}_{\mathcal{V}_X}(x)). \end{aligned}$$

Maximizing the last expression with respect to all the class variables amounts to maximizing over the identified class variables of the maximal connected components. The new maximization problems are carried out on lower dimensional subspaces than originally, thereby reducing the computational cost. Note that the feature subgraph structure is irrelevant in this process.  $\square$

<sup>1</sup> A graph is said to be connected if there is a path between every pair of vertices in its undirected version.



Given  $\mathbf{x}$ , each expression to be maximized in Eq. (3) will be denoted as  $\phi_i^{\mathbf{x}}(\mathbf{c}^{\downarrow \mathcal{V}_{c_i}})$ , i.e.

$$\phi_i^{\mathbf{x}}(\mathbf{c}^{\downarrow \mathcal{V}_{c_i}}) = \prod_{C \in \mathcal{V}_{c_i}} p(c|\mathbf{pa}(c)) \cdot \prod_{X \in \text{Ch}(\mathcal{V}_{c_i})} p(x|\mathbf{pa}_{\mathcal{V}_c}(x), \mathbf{pa}_{\mathcal{V}_x}(x))$$

It holds that  $\phi_i^{\mathbf{x}}(\mathbf{c}^{\downarrow \mathcal{V}_{c_i}}) \propto p(C^{\downarrow \mathcal{V}_{c_i}} = \mathbf{c}^{\downarrow \mathcal{V}_{c_i}}|\mathbf{x})$ .

**Example 3 (continued).** For the CB-decomposable MBC in Fig. 5(a), we have that

$$\begin{aligned} & \max_{c_1, \dots, c_5} p(C_1 = c_1, \dots, C_5 = c_5 | X_1 = x_1, \dots, X_6 = x_6) \\ & \propto \max_{c_1, \dots, c_5} p(c_1)p(c_2)p(c_3|c_2)p(c_4)p(c_5|c_4)p(x_1|c_1)p(x_2|c_1, c_2, x_1, x_3) \\ & \cdot p(x_3|c_3)p(x_4|c_3, x_3, x_5, x_6)p(x_5|c_4, c_5, x_6)p(x_6|c_5) \\ & = \left[ \max_{c_1, c_2, c_3} p(c_1)p(c_2)p(c_3|c_2)p(x_1|c_1)p(x_2|c_1, c_2, x_1, x_3)p(x_3|c_3)p(x_4|c_3, x_3, x_5, x_6) \right] \\ & \cdot \left[ \max_{c_4, c_5} p(c_4)p(c_5|c_4)p(x_5|c_4, c_5, x_6)p(x_6|c_5) \right] \\ & = \left[ \max_{c_1, c_2, c_3} \phi_1^{\mathbf{x}}(c_1, c_2, c_3) \right] \cdot \left[ \max_{c_4, c_5} \phi_2^{\mathbf{x}}(c_4, c_5) \right]. \end{aligned}$$

The use of a gray code in each maximal connected component of a CB-decomposable MBC leads to more computational savings in posterior probability computations than without this decomposability. Theorem 4 states those savings and an upper bound of  $\frac{F_{GC}}{F_{BF}}$ .

**Theorem 4.** Given a CB-decomposable MBC with  $r$  maximal connected components, where each component  $i$  has  $d_i$  class variables and  $m_i$  feature variables, the independent use of a gray code over the  $d_i$  class variables of each component  $i$ , can obtain:

- (a)  $F_{GC} = \sum_{i=1}^r (m_i + d_i + \sum_{j=1}^{d_i} S_j^i H_j^i)$
- (b)  $\frac{F_{GC}}{F_{BF}} < \frac{1}{|\mathcal{I}|} + \frac{\sum_{i=1}^r |\mathcal{I}_i| H_{Max}^i}{(m + d)|\mathcal{I}|}$ , where  $H_{Max}^i = \max_{1 \leq j \leq d_i} H_j^i$ ,  $H_j^i = 1 + h_j^i$ , and  $h_j^i$  is the number of children of the class variable that changes the  $j$ th in the gray code of component  $i$ .

**Proof.** (a) is straightforward from Theorem 2. Note that  $\sum_{i=1}^r m_i = m$ ,  $\sum_{i=1}^r d_i = d$ .

(b)  $F_{GC} \leq \sum_{i=1}^r (m_i + d_i + (|\mathcal{I}_i| - 1)H_{Max}^i)$ . Then

$$\begin{aligned} \frac{F_{GC}}{F_{BF}} & \leq \frac{\sum_{i=1}^r (m_i + d_i + (|\mathcal{I}_i| - 1)H_{Max}^i)}{(m + d)|\mathcal{I}|} \\ & < \frac{1}{|\mathcal{I}|} + \frac{\sum_{i=1}^r |\mathcal{I}_i| H_{Max}^i}{(m + d)|\mathcal{I}|} \quad \square \end{aligned}$$

**Example 3 (continued).** For the CB-decomposable MBC of Fig. 5(a), and considering that all class variables are binary, we have that  $m = 6, d = 5, m_1 = 4, d_1 = 3, m_2 = 2, d_2 = 2, |\mathcal{I}| = 32, H_1^1 = 3, H_2^1 = 2, H_3^1 = 3, H_1^2 = 2, H_2^2 = 3, H_{Max}^1 = 3, H_{Max}^2 = 3, S_1^1 = 4, S_2^1 = 2, S_3^1 = 1, S_1^2 = 2$  and  $S_2^2 = 1$ , and we get:

$$\frac{F_{GC}}{F_{BF}} = \frac{4 + 3 + 4 \cdot 3 + 2 \cdot 2 + 1 \cdot 3 + 2 + 2 + 2 \cdot 2 + 1 \cdot 3}{(6 + 5) \cdot 32} = \frac{42}{352}.$$

The upper bound is:  $\frac{F_{GC}}{F_{BF}} < \frac{1}{32} + \frac{8 \cdot 3 + 4 \cdot 3}{(6+5) \cdot 32} = \frac{47}{352}$ . This bound is better than that obtained in Theorem 2 without considering the decomposability, which is  $\frac{1}{32} + \frac{3}{11} = \frac{107}{352}$ .



#### 4. Bayes decision rule under additive CB-decomposable loss functions

This section extends the previous one, beyond 0–1 loss functions and MPE computations, by providing for other loss functions that conform to CB-decomposable structures.

**Definition 4** (Additive CB-decomposable loss function). Let  $\lambda(\mathbf{c}', \mathbf{c})$  be a loss function. Given a CB-decomposable MBC  $B$ , we say that  $\lambda$  is an additive CB-decomposable loss function according to  $B$  if

$$\lambda(\mathbf{c}', \mathbf{c}) = \sum_{i=1}^r \lambda_i(\mathbf{c}'^{\downarrow \mathcal{V}_{c_i}}, \mathbf{c}^{\downarrow \mathcal{V}_{c_i}}),$$

where  $\lambda_i$  is a non-negative loss function defined on  $\mathcal{I}_i$ .

**Theorem 5.** Let  $B$  be a CB-decomposable MBC with  $r$  maximal connected components. If  $\lambda$  is an additive CB-decomposable loss function according to  $B$ , then

$$\min_{\mathbf{c}' \in \mathcal{I}} R(\mathbf{c}' | \mathbf{x}) = \sum_{i=1}^r \left[ \min_{\mathbf{c}'^{\downarrow \mathcal{V}_{c_i}} \in \mathcal{I}_i} \sum_{\mathbf{c}^{\downarrow \mathcal{V}_{c_i}} \in \mathcal{I}_i} \lambda_i(\mathbf{c}'^{\downarrow \mathcal{V}_{c_i}}, \mathbf{c}^{\downarrow \mathcal{V}_{c_i}}) \cdot \phi_i^{\mathbf{x}}(\mathbf{c}^{\downarrow \mathcal{V}_{c_i}}) \right] \left[ \prod_{j \neq i} \sum_{\mathbf{c}^{\downarrow \mathcal{V}_{c_j}} \in \mathcal{I}_j} \phi_j^{\mathbf{x}}(\mathbf{c}^{\downarrow \mathcal{V}_{c_j}}) \right]. \quad (4)$$

**Proof**

$$\begin{aligned} \min_{\mathbf{c}' \in \mathcal{I}} R(\mathbf{c}' | \mathbf{x}) &= \min_{\mathbf{c}' \in \mathcal{I}} \sum_{\mathbf{c} \in \mathcal{I}} \lambda(\mathbf{c}', \mathbf{c}) p(\mathbf{c} | \mathbf{x}) \\ &= \min_{\mathbf{c}' \in \mathcal{I}} \sum_{i=1}^r \sum_{\mathbf{c} \in \mathcal{I}} \lambda_i(\mathbf{c}'^{\downarrow \mathcal{V}_{c_i}}, \mathbf{c}^{\downarrow \mathcal{V}_{c_i}}) \cdot \prod_{j=1}^r \phi_j^{\mathbf{x}}(\mathbf{c}^{\downarrow \mathcal{V}_{c_j}}) \\ &= \sum_{i=1}^r \min_{\mathbf{c}' \in \mathcal{I}} \left[ \left[ \sum_{\mathbf{c}^{\downarrow \mathcal{V}_{c_i}} \in \mathcal{I}_i} \lambda_i(\mathbf{c}'^{\downarrow \mathcal{V}_{c_i}}, \mathbf{c}^{\downarrow \mathcal{V}_{c_i}}) \cdot \phi_i^{\mathbf{x}}(\mathbf{c}^{\downarrow \mathcal{V}_{c_i}}) \right] \cdot \left[ \prod_{j \neq i} \sum_{\mathbf{c}^{\downarrow \mathcal{V}_{c_j}} \in \mathcal{I}_j} \phi_j^{\mathbf{x}}(\mathbf{c}^{\downarrow \mathcal{V}_{c_j}}) \right] \right] \\ &= \sum_{i=1}^r \left[ \min_{\mathbf{c}'^{\downarrow \mathcal{V}_{c_i}} \in \mathcal{I}_i} \sum_{\mathbf{c}^{\downarrow \mathcal{V}_{c_i}} \in \mathcal{I}_i} \lambda_i(\mathbf{c}'^{\downarrow \mathcal{V}_{c_i}}, \mathbf{c}^{\downarrow \mathcal{V}_{c_i}}) \cdot \phi_i^{\mathbf{x}}(\mathbf{c}^{\downarrow \mathcal{V}_{c_i}}) \right] \cdot \left[ \prod_{j \neq i} \sum_{\mathbf{c}^{\downarrow \mathcal{V}_{c_j}} \in \mathcal{I}_j} \phi_j^{\mathbf{x}}(\mathbf{c}^{\downarrow \mathcal{V}_{c_j}}) \right] \end{aligned}$$

The second equality is due to Theorem 3 and because  $\lambda$  is additive CB-decomposable. The third equality takes advantage of the fact that  $\lambda \geq 0$  and a grouping of the sums according to the domains of functions  $\phi_i^{\mathbf{x}}$  and  $\lambda_i$ . Finally, after the fourth equality, the minimum is computed over the (smaller) spaces given by  $\mathcal{I}_i$ , where the resulting functions are defined.  $\square$

**Corollary 2.** Under the conditions of Theorem 5,

$$\arg \min_{\mathbf{c}' \in \mathcal{I}} R(\mathbf{c}' | \mathbf{x}) = (\mathbf{c}^{*\downarrow \mathcal{V}_{c_1}}, \dots, \mathbf{c}^{*\downarrow \mathcal{V}_{c_r}}), \quad (5)$$

with  $\mathbf{c}^{*\downarrow \mathcal{V}_{c_i}} = \arg \min_{\mathbf{c}'^{\downarrow \mathcal{V}_{c_i}} \in \mathcal{I}_i} \sum_{\mathbf{c}^{\downarrow \mathcal{V}_{c_i}} \in \mathcal{I}_i} \lambda_i(\mathbf{c}'^{\downarrow \mathcal{V}_{c_i}}, \mathbf{c}^{\downarrow \mathcal{V}_{c_i}}) \cdot \phi_i^{\mathbf{x}}(\mathbf{c}^{\downarrow \mathcal{V}_{c_i}})$ . This sum, which is to be minimized, is the expected loss over maximal connected component  $i$ . Obviously,  $(c_1^*, \dots, c_d^*)$  is readily obtained by assembling the vector in (5) above.

**Proof.** The proof is straightforward from Theorem 5, since  $\prod_{j \neq i} \sum_{\mathbf{c}^{\downarrow \mathcal{V}_{c_j}} \in \mathcal{I}_j} \phi_j^{\mathbf{x}}(\mathbf{c}^{\downarrow \mathcal{V}_{c_j}})$  in (4) does not depend on  $i$ .  $\square$

**Example 3** (continued). Let  $\mathbf{x}$  be (0, 0, 0, 0, 0, 0). Assume we have the following probabilistic information for the CB-decomposable MBC in Fig. 5(a), where all variables (classes and features) are binary:

- For the first maximal connected component:
  - For the class variables:  $p(C_1 = 0) = 0.3$ ,  $p(C_2 = 0) = 0.6$ ,  $p(C_3 = 0 | C_2 = 0) = 0.8$ ,  $p(C_3 = 0 | C_2 = 1) = 0.4$ .
  - For the features:
    - \* For  $X_1$ ,  $p(X_1 = 0 | C_1 = 0) = 0.2$ ,  $p(X_1 = 0 | C_1 = 1) = 0.3$
    - \* For  $X_2$ ,  $p(X_2 = 0 | C_1 = 0, C_2 = 0, X_1 = 0, X_3 = 0) = 0.2$ ,  
 $p(X_2 = 0 | C_1 = 0, C_2 = 1, X_1 = 0, X_3 = 0) = 0.5$ ,

- $p(X_2 = 0|C_1 = 1, C_2 = 0, X_1 = 0, X_3 = 0) = 0.6,$
- $p(X_2 = 0|C_1 = 1, C_2 = 1, X_1 = 0, X_3 = 0) = 0.3.$
- \* For  $X_3,$   $p(X_3 = 0|C_3 = 0) = 0.5, p(X_3 = 0|C_3 = 1) = 0.7.$
- \* For  $X_4,$   $p(X_4 = 0|C_3 = 0, X_3 = 0, X_5 = 0, X_6 = 0) = 0.7,$
- $p(X_4 = 0|C_3 = 1, X_3 = 0, X_5 = 0, X_6 = 0) = 0.1.$
- For the second maximal connected component:
  - For the class variables:  $p(C_4 = 0) = 0.6, p(C_5 = 0|C_4 = 0) = 0.3, p(C_5 = 0|C_4 = 1) = 0.1.$
  - For the features:
    - \* For  $X_5,$   $p(X_5 = 0|C_4 = 0, C_5 = 0, X_6 = 0) = 0.3,$
    - $p(X_5 = 0|C_4 = 0, C_5 = 1, X_6 = 0) = 0.9,$
    - $p(X_5 = 0|C_4 = 1, C_5 = 0, X_6 = 0) = 0.8,$
    - $p(X_5 = 0|C_4 = 1, C_5 = 1, X_6 = 0) = 0.4.$
    - \* For  $X_6,$   $p(X_6 = 0|C_5 = 0) = 0.2, p(X_6 = 0|C_5 = 1) = 0.5.$

Let  $\lambda$  be an additive CB-decomposable loss function given by

$$\lambda(c'_1, \dots, c'_5, c_1, \dots, c_5) = \lambda_1(c'_1, c'_2, c'_3, c_1, c_2, c_3) + \lambda_2(c'_4, c'_5, c_4, c_5),$$

where  $\lambda_i(\mathbf{c}'^{\downarrow \mathcal{V}_{c_i}}, \mathbf{c}^{\downarrow \mathcal{V}_{c_i}}) = d_H(\mathbf{c}'^{\downarrow \mathcal{V}_{c_i}}, \mathbf{c}^{\downarrow \mathcal{V}_{c_i}})$ , with  $i = 1, 2$ , and  $d_H$  denotes the Hamming distance, i.e. the number of coordinates where  $\mathbf{c}'^{\downarrow \mathcal{V}_{c_i}}$  and  $\mathbf{c}^{\downarrow \mathcal{V}_{c_i}}$  are different. Note that in our multi-dimensional classification problem,  $d_H$  counts the total number of errors made by the classifier in the class variables. Thus,  $\lambda_1$  is

$\lambda_1$	(0,0,0)	(0,0,1)	(0,1,0)	(0,1,1)	(1,0,0)	(1,0,1)	(1,1,0)	(1,1,1)
(0,0,0)	0	1	1	2	1	2	2	3
(0,0,1)	1	0	2	1	3	1	3	2
(0,1,0)	1	2	0	1	2	3	1	2
(0,1,1)	2	1	1	0	3	2	2	1
(1,0,0)	1	3	2	3	0	1	1	2
(1,0,1)	2	1	3	2	1	0	2	1
(1,1,0)	2	3	1	2	1	2	0	1
(1,1,1)	3	2	2	1	2	1	1	0

and  $\lambda_2$  is

$\lambda_2$	(0,0)	(0,1)	(1,0)	(1,1)
(0,0)	0	1	1	2
(0,1)	1	0	2	1
(1,0)	1	2	0	1
(1,1)	2	1	1	0

We have that

$$\begin{aligned} \phi_1^{\mathbf{x}}(c_1, c_2, c_3) &= p(c_1)p(c_2)p(c_3|c_2) \\ &\cdot p(X_1 = 0|c_1)p(X_2 = 0|c_1, c_2, X_1 = 0, X_3 = 0)p(X_3 = 0|c_3) \\ &\cdot p(X_4 = 0|c_3, X_3 = 0, X_5 = 0, X_6 = 0) \end{aligned}$$

Table 1 lists the whole set of  $\phi_1^{\mathbf{x}}$  values on the left-hand side. The rest of the table develops the computations required for  $\mathbf{c}^{\downarrow \mathcal{V}_{c_i}}$  as indicated in Corollary 2. Therefore,  $\mathbf{c}^{\downarrow \{C_1, C_2, C_3\}} = (1, 0, 0)$ .

Furthermore, we have that

$$\phi_2^{\mathbf{x}}(c_4, c_5) = p(c_4)p(c_5|c_4)p(X_5 = 0|c_4, c_5, X_6 = 0)p(X_6 = 0|c_5),$$

where the associated results are shown in Table 2. Therefore,  $\mathbf{c}^{\downarrow \{C_4, C_5\}} = (0, 1)$ .

Finally, our CB-decomposable MBC assigns the class vector  $\mathbf{c}^* = (1, 0, 0, 0, 1)$  to the feature vector  $\mathbf{x} = (0, 0, 0, 0, 0, 0)$ .

**Table 1**  
Computing the minimum expected loss in the first maximal connected component.

$(c_1, c_2, c_3)$	$\phi_1^x(c_1, c_2, c_3)$	$(c'_1, c'_2, c'_3)$	$\sum_{c_1, c_2, c_3} \lambda_1 \phi_1^x$
(0, 0, 0)	0.0020160	(0, 0, 0)	0.0363048
(0, 0, 1)	0.0001008	(0, 0, 1)	0.0831432
(0, 1, 0)	0.0016800	(0, 1, 0)	0.0538776
(0, 1, 1)	0.0005040	(0, 1, 1)	0.0795480
(1, 0, 0)	0.0211680	(1, 0, 0)	0.0275016
(1, 0, 1)	0.0010584	(1, 0, 1)	0.0394632
(1, 1, 0)	0.0035280	(1, 1, 0)	0.0313656
(1, 1, 1)	0.0010584	(1, 1, 1)	0.0570360

**Table 2**  
Computing the minimum expected loss in the second maximal connected component.

$(c_4, c_5)$	$\phi_2^x(c_4, c_5)$	$(c'_4, c'_5)$	$\sum_{c_4, c_5} \lambda_2 \phi_2^x$
(0, 0)	0.0108	(0, 0)	0.3394
(0, 1)	0.1890	(0, 1)	0.0956
(1, 0)	0.0064	(1, 0)	0.4608
(1, 1)	0.0720	(1, 1)	0.2170

**Corollary 3.** Under the same assumptions as in Theorem 5 with  $r = d$  maximal connected components, then

$$\min_{\mathbf{c}' \in \mathcal{I}} R(\mathbf{c}' | \mathbf{x}) = \sum_{i=1}^d \left[ \min_{c'_i} \sum_{c_i} \lambda_i(c'_i, c_i) \cdot \phi_i^x(c_i) \right] \prod_{j \neq i} \sum_{c_j} \phi_j^x(c_j),$$

where

$$\phi_i^x(c_i) = p(c_i) \prod_{X \in \text{Ch}(c_i)} p(x | c_i, \mathbf{pa}_{V_X}(x)).$$

**Proof.** The proof is straightforward from Theorem 5. Under this decomposability, class variables are not longer conditioned to other class variables. □

Note that the simplest CB-decomposability applies in this case.

### 5. Performance evaluation metrics for multi-dimensional classifiers

We propose the following performance measures that extend metrics existing in the single-class domain. Cases  $i \in \{1, \dots, N\}$  are assumed to belong to the test data set.

(1) Mean accuracy over the  $d$  class variables:

$$\overline{Acc}_d = \frac{1}{d} \sum_{j=1}^d Acc_j = \frac{1}{d} \sum_{j=1}^d \frac{1}{N} \sum_{i=1}^N \delta(c'_{ij}, c_{ij}), \tag{6}$$

where  $\delta(c'_{ij}, c_{ij}) = 1$  if  $c'_{ij} = c_{ij}$ , and 0 otherwise. Note that  $c'_{ij}$  denotes the  $C_j$  class value outputted by the model for case  $i$  and  $c_{ij}$  is its true value.

A similar concept may be extended to CB-decomposable MBCs by means of the mean accuracy over the  $r$  maximal connected components:

$$\overline{Acc}_r = \frac{1}{r} \sum_{j=1}^r \frac{1}{N} \sum_{i=1}^N \delta(\mathbf{c}'_i \downarrow \mathcal{V}_{C_j}, \mathbf{c}_i \downarrow \mathcal{V}_{C_j}).$$

(2) Global accuracy over the  $d$ -dimensional class variable:

$$Acc = \frac{1}{N} \sum_{i=1}^N \delta(\mathbf{c}'_i, \mathbf{c}_i) \tag{7}$$

where  $\delta(\mathbf{c}', \mathbf{c}_i) = 1$  if  $\mathbf{c}'_i = \mathbf{c}_i$ , and 0 otherwise. Therefore, we call for an equality in all the components of the vector of predicted classes and the vector of real classes.

It holds that  $Acc \leq \overline{Acc}_r \leq Acc_d$ . This is obvious since it is less demanding to count errors in a component-wise fashion than as a vector of components that, as a whole, has to correctly predict all its coordinates.

If all the class variables are binary, then we also have:

(3) Macro F1:

$$\text{Macro F1} = 2 \frac{\overline{Pre}_d \times \overline{Rec}_d}{\overline{Pre}_d + \overline{Rec}_d}, \quad (8)$$

where mean precision and mean recall over the  $d$  class variables are defined, respectively, as

$$\overline{Pre}_d = \frac{1}{d} \sum_{j=1}^d Pre^j, \quad \overline{Rec}_d = \frac{1}{d} \sum_{j=1}^d Rec^j.$$

$Pre^j$  and  $Rec^j$  are the precision and recall, respectively, obtained from the single-class confusion matrix of  $C_j$ , i.e.

$Pre^j = \frac{TP^j}{TP^j + FP^j}$ ,  $Rec^j = \frac{TP^j}{TP^j + FN^j}$ , where  $TP^j$ ,  $FN^j$ ,  $TN^j$ ,  $FP^j$  are the counts for true positives, false negatives, true negatives and false positives, respectively.

(4) Micro F1:

$$\text{Micro F1} = 2 \frac{Pre^g \times Rec^g}{Pre^g + Rec^g}, \quad (9)$$

where

$$Pre^g = \frac{\sum_{j=1}^d TP^j}{\sum_{j=1}^d (TP^j + FP^j)}, \quad Rec^g = \frac{\sum_{j=1}^d TP^j}{\sum_{j=1}^d (TP^j + FN^j)},$$

which could be seen as global precision and global recall.

## 6. Learning MBCs from data

In this section we introduce algorithms to learn MBCs from data. Let  $\mathcal{D}$  be a database of  $N$  observations containing a value assignment for each variable  $X_1, \dots, X_m, C_1, \dots, C_d$ , i.e.  $\mathcal{D} = \{(\mathbf{x}^{(1)}, \mathbf{c}^{(1)}), \dots, (\mathbf{x}^{(N)}, \mathbf{c}^{(N)})\}$ . The learning problem is to find an MBC that best fits the available data. We will use a score + search approach [10] to find the MBC structure. MBC parameters can be estimated as in standard Bayesian networks. The score measuring the goodness of an MBC given  $\mathcal{D}$  can be independent of or dependent on the classifier performance measure (a filter score or a wrapper score respectively) [21,35]. Although any kind of strategy could be employed to search the MBC space, the algorithms proposed below follow a greedy search for computational reasons. The algorithms will, however, be flexible due to the possibility of incorporating filter, wrapper or hybrid approaches and because, as opposed to other proposals found in the literature, any kind of structure is allowed for the class and feature subgraphs.

### 6.1. PURE FILTER algorithm

Given a fixed ordering of all the variables  $O = (O_C, O_X) = (C_{\pi(1)}, \dots, C_{\pi(d)}, X_{\pi'(1)}, \dots, X_{\pi'(m)})$ , where  $\pi$  and  $\pi'$  are permutations over the variables in  $\mathcal{V}_C$  and  $\mathcal{V}_X$ , respectively, this algorithm first learns the class subgraph,  $\mathcal{G}_C$ , with a filter score that takes into account ordering  $O_C$  and then learns the feature subgraph,  $\mathcal{G}_X$ , using  $O_X$  in the same way, once the bridge subgraph,  $\mathcal{G}_{C_X}$ , is fixed.

The learning problem can be solved as two separate problems: (1) the search for the best structure of  $\mathcal{G}_C$ , taking into account only the  $\mathcal{D}_C = \{\mathbf{c}^{(1)}, \dots, \mathbf{c}^{(N)}\}$  values, which is solved once; and (2) the search for the best structure of  $\mathcal{G}_X$ , constrained by fixed parents in  $\mathcal{V}_C$  given in a candidate bridge subgraph  $\mathcal{G}_{C_X}$ , which is then updated via a best-first search in  $\mathcal{G}_{C_X}$ . By choosing a decomposable score, both searches, in  $\mathcal{G}_X$  and  $\mathcal{G}_{C_X}$ , may reduce their computational burden considerably since only local computations are carried out.

Considering the MBC structure, the global score  $s(\mathcal{D}|\mathcal{G})$  to be maximized, is the sum of the scores over the class variables,  $s(\mathcal{D}_C|\mathcal{G}_C)$ , and the score over the feature variables given a fixed structure  $\mathcal{G}_{C_X}$  from classes to features,  $s_{\mathcal{G}_{C_X}}(\mathcal{D}|\mathcal{G}_X)$ .

PURE FILTER algorithm

Input: An ordering  $O = (O_C, O_X)$

$i = 0$

1. [Learn class subgraph]

Learn  $\mathcal{G}_C^*$  with a filter score,  $s(\mathcal{D}_C|\mathcal{G}_C)$  based on  $O_C$ .

2. [Learn feature subgraph]

Set  $\mathcal{G}_{C_X}^{(0)} = \emptyset$ . Learn  $\mathcal{G}_X^{(0)}$  with a filter score  $s_{\mathcal{G}_{C_X}^{(0)}}(\mathcal{D}|\mathcal{G}_X^{(0)})$ , based on  $O_X$ .

3. [Propose a candidate bridge subgraph]

Add one arc to  $\mathcal{G}_{C_X}^{(i)}$  to get a candidate  $\mathcal{G}_{C_X}^{(i+1)}$ .

4. [Obtain a candidate feature subgraph]

Given the candidate  $\mathcal{G}_{C_X}^{(i+1)}$ , learn  $\mathcal{G}_X^{(i+1)}$  with the filter score  $s_{\mathcal{G}_{C_X}^{(i+1)}}(\mathcal{D}|\mathcal{G}_X^{(i+1)})$ , constrained by  $\mathcal{G}_{C_X}^{(i+1)}$ , based on  $O_X$ .

5. [Decide on the bridge and feature subgraph candidates]

If  $s_{\mathcal{G}_{C_X}^{(i+1)}}(\mathcal{D}|\mathcal{G}_X^{(i+1)}) > s_{\mathcal{G}_{C_X}^{(i)}}(\mathcal{D}|\mathcal{G}_X^{(i)})$ , update the bridge subgraph,  $i = i + 1$  and go to 3.

Else, while there are unvisited candidates, go to 3.

Otherwise,  $\mathcal{G}_X^* = \mathcal{G}_X^{(i+1)}$  and  $\mathcal{G}_{C_X}^* = \mathcal{G}_{C_X}^{(i+1)}$ , and stop.

Output:  $\mathcal{G}^* = \mathcal{G}_C^* \cup \mathcal{G}_X^* \cup \mathcal{G}_{C_X}^*$ .

Fig. 6. Pseudocode of the pure filter algorithm.

PURE WRAPPER algorithm

$i = 0$

1.  $\mathcal{G}^{(i)} = \emptyset$ .  $Acc = Acc^{(i)}$ .

2. Whenever there are arcs that can be added to  $\mathcal{G}^{(i)}$  (and not previously discarded):

Add/delete one arc to  $\mathcal{G}_C^{(i)}$ ,  $\mathcal{G}_{C_X}^{(i)}$  or  $\mathcal{G}_X^{(i)}$  and obtain the new  $\mathcal{G}^{(i+1)}$  and  $Acc^{(i+1)}$ .

3. If  $Acc^{(i+1)} > Acc^{(i)}$ ,  $Acc = Acc^{(i+1)}$ ,  $i = i + 1$ , and go to 2.

Else discard the arc and go to 2.

4. Stop and return  $\mathcal{G}^{(i)}$  and  $Acc$ .

Fig. 7. Pseudocode of the pure wrapper algorithm.

The algorithm is in Fig. 6.

Note that the MBC structure and the ancestral fixed order  $O = (O_C, O_X)$  allow us to use data from the class variables, to search for the best class subgraph,  $\mathcal{G}_C^*$ , independently of the other variables (step 1). On the other hand, we organize the search of the rest of the graph by first fixing a bridge subgraph (steps 2 and 5) and then searching for the best feature subgraph conditioned to the class parents given in the bridge subgraph (step 4). An example would be to apply a K2 algorithm over the features using  $O_X$  but with the bridge subgraph imposing some class variables as parents. Then, we move to a new bridge subgraph which is equal to the previous one except for one added arc (step 3). This greedy strategy is handy from a computational point of view, since if we use a decomposable score, the new and old scores only differ by the term involving the new arc. That is, when arc  $(C_l, X_j) \in \mathcal{A}_{C_X}$  is added to the bridge subgraph  $\mathcal{G}_{C_X}^{(i)}$  to have a candidate bridge subgraph  $\mathcal{G}_{C_X}^{(i+1)}$ , then the difference required in step 5,  $s_{\mathcal{G}_{C_X}^{(i+1)}}(\mathcal{D}|\mathcal{G}_X^{(i+1)}) - s_{\mathcal{G}_{C_X}^{(i)}}(\mathcal{D}|\mathcal{G}_X^{(i)})$ , consists of the score only evaluating  $X_j$  and its new parents.

Note that the greedy strategy is forward, starting from the empty graph (step 2). Each time a better structure (bridge + features) is found (a better score), we update the current structure with this new one –a best-first strategy– and start the forward scheme from here. The process stops when any addition to the current bridge subgraph fails to provide a feature subgraph that improves the score.

## 6.2. PURE WRAPPER algorithm

This algorithm greedily searches for one arc, to be added or removed, in any position but respecting the MBC structure, such that the global accuracy  $Acc$ , as defined in Section 5, is improved. Any general DAG structure is allowed for the class and feature subgraphs. The algorithm stops if no arcs can be added or deleted to the current structure to improve the global accuracy.

The algorithm is in Fig. 7.

This algorithm is controlled by the  $Acc$  measure. Any other performance measure defined in Section 5 could be used. However, computing  $Acc$  involves the computation of the MPE for the class variables given the features, and this has the advantage of being alleviated if there are CB-decomposable MBCs (Theorem 3), which is likely to be the case as the algorithm progresses, specially in the early stages. Also, gray codes will reduce the computations (Theorems 4 and 2).

**Special case of an additive CB-decomposable loss function.** Let  $\lambda(\mathbf{c}', \mathbf{c})$  be an additive CB-decomposable loss function according to a CB-decomposable MBC  $B$  with  $r$  maximal connected components. Then the PURE WRAPPER algorithm can be

applied with the following modifications. The global accuracy  $Acc$  counts the number of correctly classified cases based on the real and predicted class vectors. However, since the loss function is no any longer 0-1, the predicted class vector for each  $\mathbf{x}$  is obtained by minimizing its expected loss  $R(\mathbf{c}|\mathbf{x})$ . When  $\lambda$  is additive CB-decomposable, Theorems 4 and 5 and Corollary 2 provide computational savings via gray codes and MBC decomposability, which would be beneficial in step 2 of the algorithm. Moreover, when trying to move to a new structure at step 2, if  $\lambda$  is additive CB-decomposable, the added/deleted arc should guarantee that a CB-decomposable MBC with  $r$  maximal connected components according to  $\lambda$  is yielded. This means that the class subgraph is constrained by only allowing arcs among class variables of the same group  $\mathcal{V}_{C_i}$ ,  $i = 1, \dots, r$  defined by  $\lambda$ . It also means that the non-shared children property for the  $r$  components should hold. Note that our forward strategy starting from the empty structure will produce structures with  $h > r$  maximal connected components in the early iterations. These structures will be valid as long as they do not contradict the groups of class variables given by  $\lambda$ .

6.3. HYBRID algorithm

This algorithm is equal to the PURE FILTER algorithm but the decision on the candidate structures at step 5 is made based on the global accuracy  $Acc$  (or any other performance measure), rather than on a general score  $s$ .

6.4. Cardinality of MBC structure space

The above learning algorithms move within the MBC structure space. Thus, knowledge of the cardinality of this space can help us to infer the complexity of the learning problem. We will point out two cases. The first one is the general MBC, whereas the second one places two constraints on the MBC bridge subgraph sometimes found in the literature [70,15].

**Theorem 6.** The number of all possible MBC structures with  $d$  class variables and  $m$  feature variables,  $MBC(d, m)$ , is

$$MBC(d, m) = S(d) \cdot 2^{dm} \cdot S(m),$$

where  $S(n) = \sum_{i=1}^n (-1)^{i+1} \binom{n}{i} 2^{i(n-i)} S(n-i)$  is Robinson's formula [50] that counts the number of possible DAG structures of  $n$  nodes, which is initialized as  $S(0) = S(1) = 1$ .

**Proof.**  $S(d)$  and  $S(m)$  count the possible DAG structures for the class subgraph and feature subgraph, respectively.  $2^{dm}$  is the number of possible bridge subgraphs. □

We now consider MBCs satisfying the following conditions on their bridge subgraph: (a) for each  $X_i \in \mathcal{V}_X$ , there is a  $C_j \in \mathcal{V}_C$  with  $(C_j, X_i) \in \mathcal{A}_{C,X}$  and (b) for each  $C_j \in \mathcal{V}_C$ , there is an  $X_i \in \mathcal{V}_X$  with  $(C_j, X_i) \in \mathcal{A}_{C,X}$ . These conditions were used in van der Gaag and de Waal [70] and in de Waal and van der Gaag [15] for learning tree-tree and polytree-polytree MBCs, respectively. The number of possible bridge subgraphs is given by the following theorem.

**Theorem 7.** The number of all possible bridge subgraphs,  $BRS(d, m)$ ,  $m \geq d$ , for MBCs satisfying the two previous conditions (a) and (b) is given by the recursive formula

$$BRS(d, m) = 2^{dm} - \sum_{k=0}^{m-1} \binom{dm}{k} - \sum_{k=m}^{dm} \sum_{\substack{x \leq d, y \leq m \\ k \leq xy \leq dm-d}} \binom{d}{x} \binom{m}{y} BRS(x, y, k),$$

where  $BRS(x, y, k)$  denotes the number of bridge subgraphs with  $k$  arcs in an MBC with  $x$  class variables and  $y$  feature variables which is initialized as  $BRS(1, 1, 1) = BRS(1, 2, 2) = BRS(2, 1, 2) = 1$ .

**Proof.** It holds that

$$\begin{aligned} BRS(d, m) &= \sum_{k=\max\{d,m\}=m}^{dm} BRS(d, m, k) \\ &= \sum_{k=m}^{dm} \left[ \binom{dm}{k} - \sum_{\substack{x \leq d, y \leq m \\ k \leq xy \leq dm-d}} \binom{d}{x} \binom{m}{y} BRS(x, y, k) \right] \\ &= 2^{dm} - \sum_{k=0}^{m-1} \binom{dm}{k} - \sum_{k=m}^{dm} \sum_{\substack{x \leq d, y \leq m \\ k \leq xy \leq dm-d}} \binom{d}{x} \binom{m}{y} BRS(x, y, k) \end{aligned}$$

The first equality is true since resulting MBCs must satisfy the two conditions on the bridge subgraphs, requiring at least  $k = \max\{d, m\} = m$  arcs. In the second equality,  $BRS(d, m, k)$  is computed by subtracting the bridge subgraphs not satisfying the two required conditions from the number of possible bridge subgraphs with  $k$  arcs, which is  $\binom{dm}{k}$ . These “invalid” bridge subgraphs include arcs from  $x$  class variables to  $y$  feature variables, such that  $x \leq d$ ,  $y \leq m$  and  $k \leq xy \leq dm - d$ .  $xy$  must be at least  $k$  to have  $k$  arcs in the bridge subgraph. Also,  $xy$  must be lower than  $dm - d + 1$ , which is the maximum number of arcs for a valid bridge subgraph. Finally, the third equality is straightforward from the expansion of  $(1 + 1)^{dm}$ .  $\square$

**Theorem 8.** *The number of all possible MBC structures with  $d$  class variables and  $m$  feature variables,  $m \geq d$ , satisfying conditions (a) and (b),  $MBC^{ab}(d, m)$  is*

$$MBC^{ab}(d, m) = S(d) \cdot BRS(d, m) \cdot S(m).$$

**Proof.** The proof is straightforward from Theorems 6 and 7.  $\square$

**Corollary 4.** *The number of all possible MBC structures with  $d$  class variables and  $m$  feature variables satisfies*

$$O(MBC(d, m)) = O(MBC^{ab}(d, m)) = 2^{dm} (\max\{d, m\})^{2^{O(\max\{d, m\})}}.$$

**Proof.** The complexity of Robinson’s formula [50] was shown to be super exponential, i.e.  $O(S(n)) = n^{2^{O(n)}}$ . Also,  $O(BRS(d, m)) = 2^{dm}$ . Therefore,

$$\begin{aligned} O(MBC(d, m)) &= O(MBC^{ab}(d, m)) = d^{2^{O(d)}} \cdot 2^{dm} \cdot m^{2^{O(m)}} \\ &\leq (\max\{d, m\})^{2 \cdot 2^{O(\max\{d, m\})}} \cdot 2^{dm} = 2^{dm} (\max\{d, m\})^{2^{O(\max\{d, m\})}} \quad \square \end{aligned}$$

## 7. Experimental results on MPE

An upper bound for the number of factors saved when computing the posterior probabilities of the MPE with gray codes was given in Section 3. This obviously has an effect on the required time. Here we compare the efficiency of the gray codes against a brute force approach as exact algorithms for MPE computation.

The experiment consists of randomly generating 12 different MBCs with a number of binary class variables ranging from  $d = 3$  to  $d = 14$  and with  $m = 10$  binary feature variables. First, a DAG generator produces a general class subgraph and a general feature subgraph. Second, the bridge subgraph is randomly generated. A data set with 10,000 cases is finally simulated from the resulting MBC via probabilistic logic sampling [29]. We then compute ten MPE problems as in Eq. (2), given ten random evidences  $\mathbf{x}^{(1)}, \dots, \mathbf{x}^{(10)}$ . For the gray codes, computations are based on Corollary 1.

Fig. 8 shows error bars for computation times when using both exact approaches. They are obtained from the average times over the ten MPE problems and the 12 different MBCs minus/plus the standard deviation.

Note that the gray code approach is faster than brute force, and this effect is more significant as the number of class variables,  $d$ , increases. This is consistent with the bounds computed in Section 3, since  $\mathcal{I}$  and  $d$  appear in the denominator of Theorem 2.

## 8. Experimental results on learning MBCs

### 8.1. Data sets

For the purpose of our study, we use three benchmark data sets.<sup>2</sup> **Emotions** data set [62] includes 593 sound clips from a 30-seconds sequence after the initial 30 seconds of a song. The 72 features extracted fall into two categories: 8 rhythmic features and 64 timbre features. Songs are categorized by six class variables: amazed-surprised, happy-pleased, relaxing-calm, quiet-still, sad-lonely, and angry-aggressive.

The **Scene** data set [4] has 2407 pictures, and their semantic scenes have to be classified into six class binary variables: beach, sunset, foliage, field, mountain, and urban. The 294 features correspond to spatial color moments in the LUV space.

The **Yeast** data set [23] is about predicting the 14 functional classes of 2417 genes in the *Saccharomyces Cerevisiae* Yeast. Each gene is described by the concatenation of microarray expression data and a phylogenetic profile given by 103 features.

All class variables are binary. The details of the three data sets are summarized in Table 3.

However, feature variables are numeric. Since MBCs are defined for discrete variables, it is necessary to discretize all the continuous features. We use a static, global, supervised and top-down discretization algorithm called class-attribute contingency coefficient [7]. The **Emotions** and **Scene** data sets contain some missing records. Missing records in the class

<sup>2</sup> Databases are available at: <http://mlkd.csd.auth.gr/multilabel.html>.



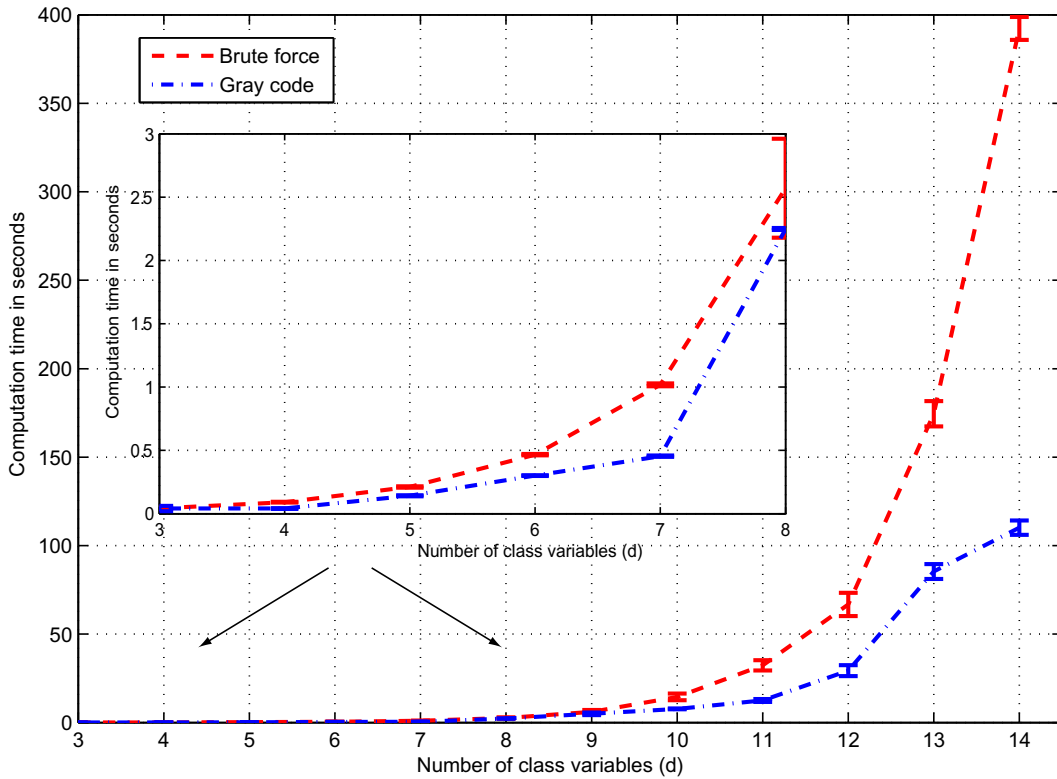

Fig. 8. Error bars for running times when MPE is computed with gray code (blue) and brute force (red) approaches.

**Table 3**  
Basic information of the three data sets.

Data set	Domain	Size	$m$	$d$
Emotions	Music	593	72	6
Scene	Vision	2407	294	6
Yeast	Biology	2417	103	14

variables (only 0.16% for *Scene* and none for *Emotions*) were removed for MPE computations. When there are missing values in the feature variables (0.15% for *Scene* and 0.11% for *Emotions*), MPE computations are carried out after their imputation. In the estimation of (conditional) probabilities, we only consider the cases with no missing values for the variables involved.

## 8.2. Experimental setup

We use eight different algorithms to learn MBCs. First, we apply five algorithms explicitly designed for MBCs: *TREE-TREE* [70], *POLYTREE-POLYTREE* [15] and *PURE FILTER*, *PURE WRAPPER* and *HYBRID* described in Section 6. *PURE FILTER* and *HYBRID* are implemented using the *K2* algorithm. Second, we use two greedy search algorithms that learn a general Bayesian network, one guided by the *K2* metric [10] (filter approach), and the other guided by a performance evaluation metric, as defined in Section 5 (wrapper approach). The first one will be denoted *K2 BN*, while the second one will be *WRAPPER BN*. Algorithms *PURE FILTER*, *HYBRID* and *K2 BN* require an ancestral ordering over the variables. We choose the best one after trying 1000 random orderings for *Emotions* and *Scene* and 100 random orderings for *Yeast*, which has more class variables. Third, we consider a multi-label lazy learning approach named *ML-KNN* [72], see Section 9.1, derived from the traditional *K*-nearest neighbor algorithm. In this case, we set *K* to 3 in the *Emotions* and *Scene* data sets, and 5 in the *Yeast* data set. As explained in Section 9.4, since it is unfeasible to compute the mutual information of two features given *all* the class variables, as required in [15], we decided to implement the *POLYTREE-POLYTREE* learning algorithm using the (marginal) mutual information of pairs of features. The heuristic searches always terminate after 200 unsuccessful trials looking for better structures, for *Emotions* and *Scene*, and just 20 trials for *Yeast*.

The probabilities attached to each node in the learnt network are calculated by maximum likelihood estimation, corrected with Laplace smoothing. As regards MPE computations required in the performance evaluation metrics, we use gray codes for all the data sets. The estimation method for performance evaluation metrics is 10-fold cross validation [58].

**Table 4**

Estimated performance metrics (mean  $\pm$  std deviation) and rank (in brackets) of the eight learning algorithms over the Emotions, Scene and Yeast data sets using 10-fold cross validation.

	Mean accuracy	Global accuracy	Macro F1	Micro F1
<b>Emotions</b>				
TREE-TREE	0.8300 $\pm$ 0.0151 (2)	0.3844 $\pm$ 0.0398 (1)	0.7921 $\pm$ 0.0273 (3)	0.8072 $\pm$ 0.0225 (2)
POLYTREE-POLYTREE	0.8209 $\pm$ 0.0243 (4)	0.3776 $\pm$ 0.0622 (2)	0.7829 $\pm$ 0.0264 (4)	0.7915 $\pm$ 0.0329 (4)
PURE FILTER	0.7548 $\pm$ 0.0280 (7)	0.2866 $\pm$ 0.0495 (6)	0.7106 $\pm$ 0.0363 (7)	0.7243 $\pm$ 0.0370 (7)
PURE WRAPPER	0.8333 $\pm$ 0.0123 (1)	0.3708 $\pm$ 0.0435 (3)	0.9145 $\pm$ 0.1107 (2)	0.8077 $\pm$ 0.0189 (1)
HYBRID	0.8210 $\pm$ 0.0170 (3)	0.3557 $\pm$ 0.0435 (4)	0.7580 $\pm$ 0.0342 (5)	0.7898 $\pm$ 0.0446 (5)
K2 BN	0.7751 $\pm$ 0.0261 (6)	0.2812 $\pm$ 0.0799 (7)	0.7315 $\pm$ 0.0351 (6)	0.7429 $\pm$ 0.0363 (6)
WRAPPER BN	0.7985 $\pm$ 0.0200 (5)	0.3033 $\pm$ 0.0752 (5)	1.0000 $\pm$ 0.0000 (1)	0.7932 $\pm$ 0.0284 (3)
ML-KNN	0.6133 $\pm$ 0.0169 (8)	0.0254 $\pm$ 0.0120 (8)	0.3428 $\pm$ 0.0368 (8)	0.3385 $\pm$ 0.0455 (8)
<b>Scene</b>				
TREE-TREE	0.7324 $\pm$ 0.0359 (7)	0.1857 $\pm$ 0.0977 (6)	0.3705 $\pm$ 0.1110 (5)	0.3465 $\pm$ 0.1256 (6)
POLYTREE-POLYTREE	0.7602 $\pm$ 0.0663 (6)	0.2643 $\pm$ 0.1915 (4)	0.3942 $\pm$ 0.1362 (4)	0.4181 $\pm$ 0.2105 (5)
PURE FILTER	0.7726 $\pm$ 0.0700 (4)	0.3067 $\pm$ 0.1991 (1)	0.3494 $\pm$ 0.1263 (7)	0.4560 $\pm$ 0.2161 (3)
PURE WRAPPER	0.7765 $\pm$ 0.0580 (2)	0.2688 $\pm$ 0.1642 (3)	1.0000 $\pm$ 0.0000 (1)	0.4893 $\pm$ 0.2436 (1)
HYBRID	0.7229 $\pm$ 0.0442 (8)	0.1570 $\pm$ 0.1018 (7)	0.2593 $\pm$ 0.1491 (8)	0.2979 $\pm$ 0.1500 (7)
K2 BN	0.7689 $\pm$ 0.0692 (5)	0.2883 $\pm$ 0.1995 (2)	0.3571 $\pm$ 0.1272 (6)	0.4477 $\pm$ 0.2235 (4)
WRAPPER BN	0.7739 $\pm$ 0.0492 (3)	0.2277 $\pm$ 0.1372 (5)	0.9446 $\pm$ 0.1751 (2)	0.4612 $\pm$ 0.2029 (2)
ML-KNN	0.8196 $\pm$ 0.0092 (1)	0.0311 $\pm$ 0.0147 (8)	0.6055 $\pm$ 0.5076 (3)	0.0567 $\pm$ 0.0233 (8)
<b>Yeast</b>				
TREE-TREE	0.7687 $\pm$ 0.0065 (3)	0.2162 $\pm$ 0.0406 (1)	0.5112 $\pm$ 0.0631 (1)	0.6833 $\pm$ 0.0351 (1)
POLYTREE-POLYTREE	0.7181 $\pm$ 0.0288 (7)	0.1278 $\pm$ 0.0349 (5)	0.4947 $\pm$ 0.0234 (2)	0.6517 $\pm$ 0.0256 (6)
PURE FILTER	0.7514 $\pm$ 0.0059 (5)	0.1254 $\pm$ 0.0210 (6)	0.4404 $\pm$ 0.0089 (5)	0.6711 $\pm$ 0.0084 (4)
PURE WRAPPER	0.7920 $\pm$ 0.0187 (1)	0.1738 $\pm$ 0.0391 (2)	0.4840 $\pm$ 0.0552 (3)	0.6812 $\pm$ 0.0310 (2)
HYBRID	0.7455 $\pm$ 0.0351 (6)	0.1312 $\pm$ 0.0404 (4)	0.4287 $\pm$ 0.0325 (7)	0.6427 $\pm$ 0.0154 (7)
K2 BN	0.7567 $\pm$ 0.0104 (4)	0.1465 $\pm$ 0.0252 (3)	0.4539 $\pm$ 0.0119 (4)	0.6760 $\pm$ 0.0181 (3)
WRAPPER BN	0.7712 $\pm$ 0.0052 (2)	0.1157 $\pm$ 0.0159 (7)	0.4377 $\pm$ 0.0429 (6)	0.6588 $\pm$ 0.0384 (5)
ML-KNN	0.6364 $\pm$ 0.0196 (8)	0.0062 $\pm$ 0.0029 (8)	0.3077 $\pm$ 0.0273 (8)	0.3218 $\pm$ 0.0460 (8)

**Table 5**

Average rankings of the eight algorithms over four metrics and three data sets.

	Mean Acc.	Global Acc.	Macro F1	Micro F1	Ave ranking
TREE-TREE	4.00	2.66	3.00	3.00	3.16
POLYTREE-POLYTREE	5.66	3.66	3.33	5.00	4.41
PURE FILTER	5.33	4.33	6.33	4.66	5.16
PURE WRAPPER	1.33	2.66	2.00	1.33	1.83
HYBRID	5.66	5.00	6.66	6.33	5.91
K2 BN	5.00	4.00	5.33	4.33	4.66
WRAPPER BN	3.33	5.66	3.00	3.33	3.83
ML-KNN	5.66	8.00	6.33	8.00	7.00

### 8.3. Results

Table 4 shows the results of the eight algorithms over the three data sets. Mean values and standard deviations are listed for each metric. The number in brackets is the rank of the algorithm in decreasing order of performance (i.e. 1=best performance, 8=worst performance).

The average ranking of the eight algorithms is presented in Table 5. The algorithms are ordered as follows: PURE WRAPPER  $>$  TREE-TREE  $>$  WRAPPER BN  $>$  POLYTREE-POLYTREE  $>$  K2 BN  $>$  PURE FILTER  $>$  HYBRID  $>$  ML-KNN.

There are several non-parametric statistical tests and procedures to compare the performance of classifiers over multiple data sets. Following García and Herrera [25], we recommend Nemenyi's test, and Holm's, Shaffer's static and Bergmann-Hommel's procedures to conduct all pairwise comparisons in a multiple comparison analysis. The authors detail how to obtain adjusted and comparable p-values in such multiple comparison procedures.

The adjusted p-values are compared against a significance level of  $\alpha = 0.05$  to reject or accept the null hypothesis stating that a pair of algorithms perform equally. By observing the significance of the tests in Holm's, Shaffer's static and Bergmann-Hommel's procedures, which are the most powerful, the conclusions are: (1) PURE WRAPPER turns out to be significantly better than K2 BN, PURE FILTER, HYBRID and ML-KNN; (2) TREE-TREE is significantly better than ML-KNN; and (3) WRAPPER BN is better than ML-KNN. Nemenyi's procedure provides the same results given in (1), (2) and (3), except for the pair PURE WRAPPER and K2 BN, whose difference in performance is not statistically significant. Note that for these data sets, all concerning multi-label classification, the state-of-the-art algorithm ML-KNN has been beaten by three algorithms not specifically designed for a multi-label setting.

In short, one of the new algorithms proposed here, PURE WRAPPER, TREE-TREE [70], and the general WRAPPER BN turn out to be the best algorithms, where PURE WRAPPER is the most outstanding of the three.

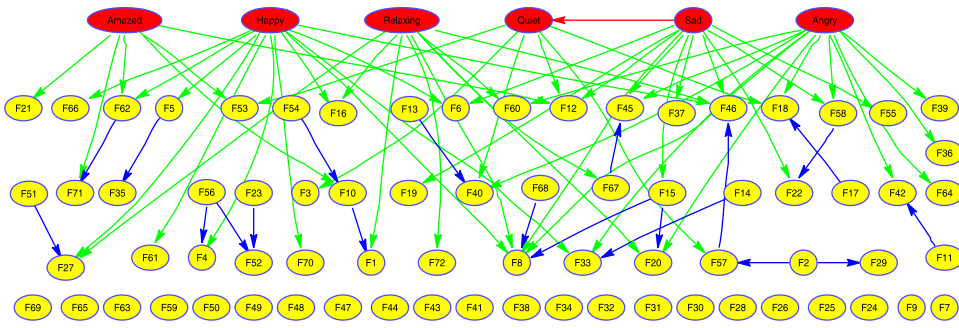

(a) PURE WRAPPER

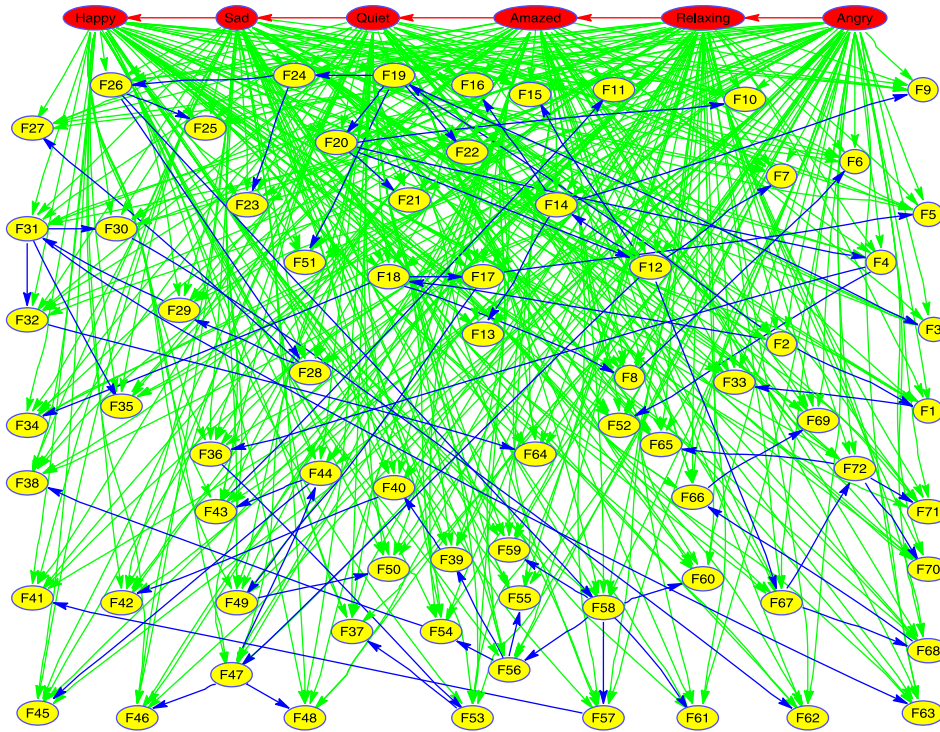

(b) TREE-TREE

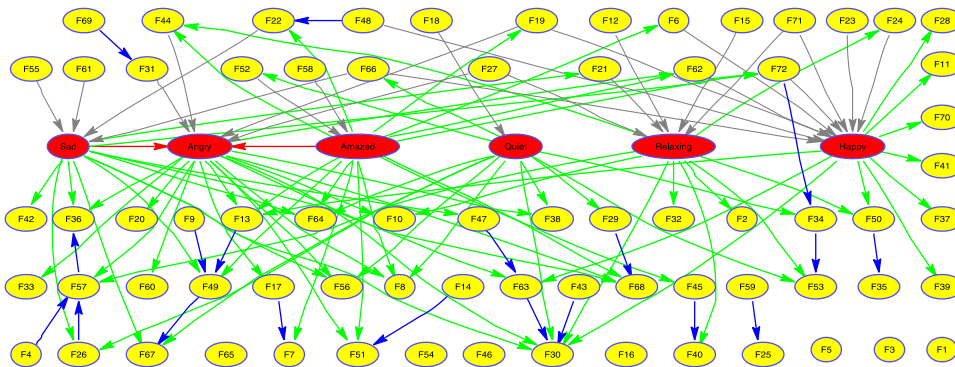

(c) WRAPPER BN

Fig. 9. Graphical structures learnt with the best algorithms for the Emotions data set.

We present some examples of the networks learnt with the best three algorithms. Fig. 9 shows three networks learnt from the Emotions data set: with PURE WRAPPER, TREE-TREE and WRAPPER BN algorithms. Red nodes represent class variables,

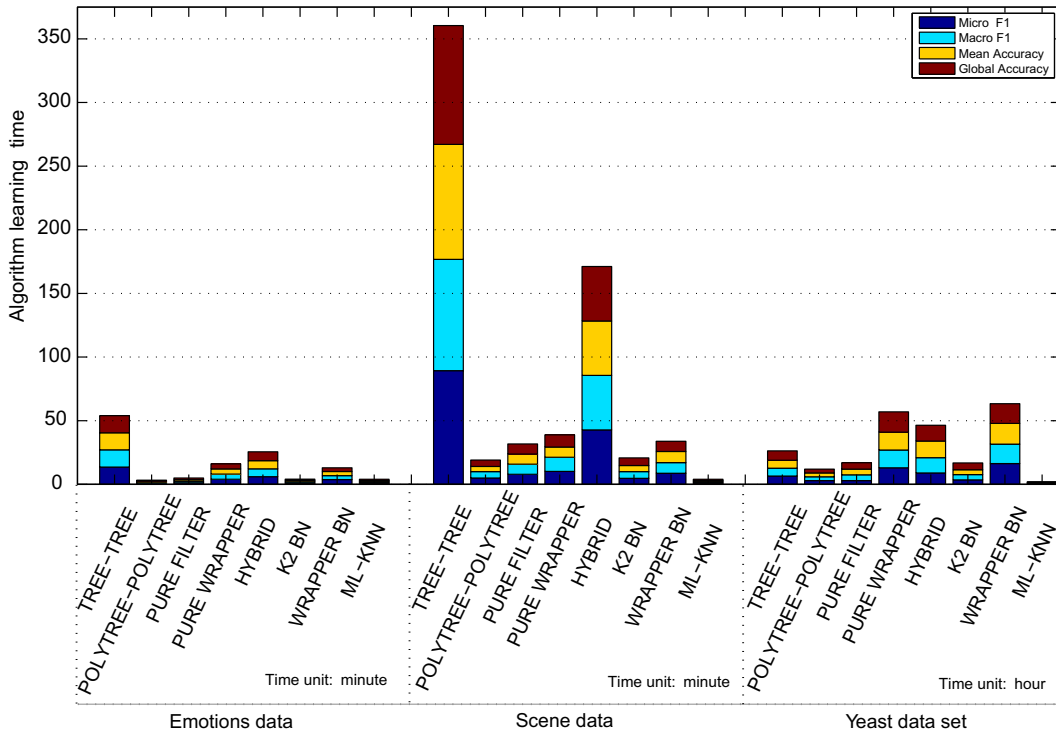

Fig. 10. Computation times of the learning process with the eight algorithms when using each performance metric for each data set.

yellow nodes are feature variables, red arrows represent arcs in the class subgraph, blue arrows represent arcs in the feature subgraph and green arrows represent arcs in the bridge subgraph. Note that arrows from features to class variables are allowed in WRAPPER BN. They are shown in gray.

Note that, in these examples, PURE WRAPPER and WRAPPER BN yield sparser networks than TREE-TREE. This behavior holds in general for the other data sets and performance evaluation metrics. This is because our specific implementation allows to add many arcs to the bridge subgraph at a time.

Finally, computation times of the learning process with the eight algorithms are shown in Fig. 10. Fig. 10 illustrates the computation time of each algorithm when using each performance metric for each data set. TREE-TREE takes the longest for Emotions and Scene, whereas ML-KNN is always the fastest. The addition of many arcs in the TREE-TREE bridge subgraph slows down the learning process since the MPE computations cannot take advantage of the alleviations explained above. Generally speaking, the algorithms using a filter approach, such as POLYTREE-POLYTREE, K2 BN and PURE FILTER, require less computation, whereas those using a wrapper approach take more computation.

All the experiments have been run on an Intel Core 2, running at 2.40 GHz, with 3.5 GB RAM using Linux operating system and Matlab parallel programming.

## 9. Related work

In this section we review works proposed for approaching multi-dimensional classification problems. The review is organized into four subsections, discussing research addressing multi-label classification, structured prediction, multiple fault diagnosis with Bayesian networks and multi-dimensional Bayesian networks classifiers, respectively. In the last section, containing works quite closely related to our proposal, we stress the similarities and dissimilarities between our research and the state-of-the-art.

### 9.1. Multi-label classification

Multi-label learning has recently originated from modern applications like text and music categorization, protein function and semantic scene classification, where each instance is associated with a subset of labels (present in the instance) from a set of  $d$  labels. Therefore, the cardinality of this subset varies depending on the instance. The aim is to build a model able to predict the subset of labels for each unseen instance. The problem can be cast into a multi-dimensional classification problem where all class variables are binary. The particular semantics of the problem requires the use of different metrics than are used in traditional single-label classification, like Hamming loss, one-error, coverage, ranking loss and average precision.

Overviews of multi-label classification are given in [65,14,67]. They are divided into two main categories: (a) problem transformation methods, and (b) algorithm adaptation methods.

Methods in (a) transform the multi-label classification problem into either one or more single-label classification problems. Examples include binary relevance [27], ranking via single-label learning [27], pairwise methods like ranking by pairwise comparison [30] and calibrated label ranking [30], methods that combine labels like label powerset [4] and pruned sets [47], ensemble methods like random  $k$ -label sets [68] and ensemble of pruned sets [47], methods that search for label dependencies like correlation-based pruning of stacked binary relevance models [64], Chi-square tests to obtain a classifier or an ensemble of classifiers –each built over a label set partition [61], and hierarchy of multi-label classifiers with sets of labels identified via clustering [66].

Methods in (b) extend specific learning algorithms to handle multi-label data directly. Different models have been proposed, including decision trees [71], support vector machines [23],  $k$ -nearest neighbor [72],  $k$ -nearest neighbor combined with Mallows probability distribution for permutations [6], a hybrid of logistic regression and  $k$ -nearest neighbor [5], neural networks [73], probabilistic chain classifier [20], generative parametric mixture model [69], and boosting [55].

### 9.2. Structured prediction

Structured prediction is a framework for solving classification and regression problems in which the output variables are constrained. The output space consists of structured objects, such as sequences, strings, trees, lattices or graphs. The aim is to learn functional dependencies for these complex output spaces, i.e. to compute the structure that maximizes some function of an input parameterized by a weight vector. Methods are based on likelihood like conditional random fields [59], on max-margin [60,63], and on search [12]. The state-of-the-art of structured prediction is given in [2] and in a recent special issue [41].

### 9.3. Multiple fault diagnosis with Bayesian networks

A related field is the diagnosis of systems with multiple faults. These systems are devices composed of components (class variables) that can be in either good or failing condition and there are some input/output variables (feature variables) related to the system function. The aim is to find the failing component, or the set of failing components, that explains the observed breakdown. From a probabilistic viewpoint this problem is equivalent to Eq. (2), a multi-dimensional classification problem where, as in multi-label classification, all class variables are binary. This is a difficult problem due to the reliability of such systems, where very few breakdown scenarios have been recorded.

Bayesian networks have been used in this context. However, most researchers build these networks systematically by taking advantage of the logical relationships among the variables included in the (physical) devices. A consequence is that only causal networks, a special case of Bayesian networks, are used [43,44]. Moreover, the structure and conditional probabilities are not learnt from data but from experts or by supplied specifications. This is the case of Darwiche [11] and Iburgüengoytia et al. [32] for example. Neither of them compute the posterior probabilities of the multiple diagnosis. In contrast, Delcroix et al. [19] try to do this, but by assuming a hypothesis of strong independence among class variables.

### 9.4. Multi-dimensional Bayesian networks classifiers

To the best of our knowledge, there are four papers that are quite closely related to our proposal: Qazi et al. [46], van der Gaag and de Waal [70], de Waal and van der Gaag [15] and Rodríguez and Lozano [51]. They all learn the structure from data constrained to a pre-set family of MBCs.

Qazi et al. [46] propose learning a DAG-empty MBC to predict heart wall motion for the 16 segments (class variables) of the heart. Once the DAG for the class subgraph is learnt by standard Bayesian networks procedures, a naïve Bayes model containing a subset of feature variables is obtained for each class variable using different features for each naïve Bayes model to finally build the corresponding bridge subgraph.

Van der Gaag and de Waal (2006) use tree-tree MBCs as follows. They prove that the score+search learning strategy based on the MDL score can be decomposed into optimization problems for the set of class variables and for the set of feature variables separately. The class subgraph is firstly learnt by searching for the maximum weighted undirected spanning tree and transforming it into a directed tree using Chow and Liu's algorithm [8]. The weight of an edge is the mutual information between a pair of class variables. For a fixed bridge subgraph, the feature subgraph is then learnt by building a maximum weighted directed spanning tree [9]. The weight of an arc is the conditional mutual information between pairs of feature variables given the parents (classes) of the second feature determined by the bridge subgraph. Unlike these two filter learning processes, the bridge subgraph is greedily changed in a wrapper-like way, trying to improve the accuracy  $Acc$  as defined in Eq. (7).  $Acc$  is the measure used to assess the quality of the learnt tree-tree MBC.

De Waal and van der Gaag (2007) theoretically find the conditions for the optimal recovery of polytree structures in class and features subgraphs for the case of polytree-polytree MBCs. The algorithms for learning the polytrees for the class and feature subgraphs separately are based on Rebane and Pearl's algorithm [48], although for the feature subgraph the algorithm requires considering all the class variables in the conditional mutual information, which is unfeasible in real



applications. This theoretical work does not state how the `polytree-polytree` MBC is learnt because it omits how to find the bridge subgraph.

Rodríguez and Lozano [51] extend polytrees to  $k$ -DB structures for class and features subgraphs (a special DAG-DAG MBC). Each permitted structure is coded as an individual in a genetic algorithm with three substrings, one per subgraph. The objective function is a vector with the accuracies  $Acc_j$  (see Eq. (6)) as components. Comparing MBCs amounts to finding non-dominated structures according to this multi-objective fitness function, NSGA-II [16] being the chosen multi-objective genetic algorithm.

Unlike these approaches, our proposal defines a unified framework allowing any Bayesian network structure in the three subgraphs of an MBC. CB-decomposable MBCs in conjunction with a gray code for enumerating the joint configurations of all the class variables in a special order, alleviate the computational burden when calculating the MPE. The framework has been extended beyond the 0–1 loss function, to general loss functions, where the additive CB-decomposable functions exploit the structure decomposition to the utmost. While the learning approaches of the MBCs are filter-based for Qazi et al. [46], hybrid for van der Gaag and de Waal [70] and wrapper for Rodríguez and Lozano [51], our framework allows the three strategy types. Also, we have introduced several performance evaluation metrics of the MBC models, useful for wrapper-based algorithms as well as for the quality assessment of the final model. Finally, note that the data sets tested in two of these papers are relatively small ( $d = 3$  and  $m = 40$  in [70],  $d = 2$  and  $m = 58$  in [51]) compared with our experiments. A similar size is used in [46] ( $d = 16$  and  $m = 216$ ), although their structure does not permit dependencies between the feature variables (96 in the final model). De Waal and van der Gaag (2007) do not present any experimental results.

## 10. Conclusions and future research

This paper approaches the multi-dimensional classification problem using a type of probabilistic graphical models named multi-dimensional Bayesian network classifiers. In MBCs, the multi-dimensional classification problem is equivalent, for a 0–1 loss function, to the search for the most probable explanation, which has shown to be a NP-hard problem.

We introduce a new type of MBCs, the so-called class-bridge (CB) decomposable MBCs that alleviates the computational burden for computing MPEs. Also, thanks to an adaptation of the gray code, we can reduce this complexity in both general MBCs and CB-decomposable MBCs even further. Upper bounds for the reductions are obtained for both types of models. Theoretical results on how to obtain the Bayes decision rule for general MBCs in the case of 0–1 loss functions and in the case of additive loss functions for CB-decomposable MBCs are proved. The paper also extends some usual performance evaluation measures (accuracy and F1 measure), previously defined for the single-class domain, to this multi-dimensional setting. Finally, flexible algorithms for learning MBCs from data are shown. Flexibility refers to the different families of permitted MBCs (e.g. `tree-tree`, `polytree-polytree`, `DAG-DAG`, `DAG-polytree`, etc.), as well as to the filter, wrapper and hybrid approaches considered to carry out the learning process. We also provide theoretical results counting the number of all possible MBC structures, that is, the cardinality of the search space for the learning task. Empirical results on the application of these learning algorithms to three data sets taken from the literature on multi-label classification problems are encouraging, beating a state-of-the-art algorithm in this multi-label setting.

This work can be extended and improved in several ways. The consideration of problems when the vector of variables to be predicted includes discrete, as well as continuous variables (classification and regression problems), is a line for a possible extension of the current approach. To avoid the discretization of the feature variables any other possibility for generalizing this paper would be to allow discrete and continuous variables in the feature subgraph [45].

A characteristic of real-world data sets is the inclusion of instances with missing data. Thus, the adaptation of the EM algorithm to the two-layer architecture of MBCs (or to the more sophisticated CB-decomposable MBC structures) is another line for future research.

The parameters of an MBC are estimated from data and can be inaccurate, especially due to the data sparseness. For this reason the sensitivity of the joint posterior probability of interest to parameter variation needs to be studied. This would be harder than in the simplest naïve Bayes classifier case [49].

We also intend to look at the definition of concept drift for multi-dimensional classification problems in data stream scenarios, and the development of the respective detection procedures for MBCs in the future.

## Acknowledgments

Research partially supported by the Spanish Ministry of Science and Innovation, projects TIN2010-20900-C04-04 and TIN2008-06815-C02-02, Consolider Ingenio 2010-CSD2007-00018 and Cajal Blue Brain. The second author was supported by UPM Sino-Spanish Research Scholarship Program.

## References

- [1] A.M. Abdelbar, S.M. Hedetniemi, Approximating MAP for belief networks is NP-hard and other theorems, *Artificial Intelligence* 102 (1) (1998) 21–38.
- [2] G.H. Bakir, T. Hofmann, B. Schölkopf, A. Smola, B. Taskar, *Predicting Structured Data*, MIT Press, Cambridge, 2007.

- [3] R. Blanco, I. Inza, M. Merino, J. Quiroga, P. Larrañaga, Feature selection in Bayesian classifiers for the prognosis of survival of cirrhotic patients treated with TIPS, *Journal of Biomedical Informatics* 38 (5) (2005) 376–388.
- [4] M.R. Boutell, J. Luo, X. Shen, C.M. Brown, Learning multi-label scene classification, *Pattern Recognition* 37 (9) (2004) 1757–1771.
- [5] W. Cheng, E. Hüllermeier, Combining instance-based learning and logistic regression for multilabel classification, *Machine Learning* 76 (2–3) (2009) 211–225.
- [6] W. Cheng, E. Hüllermeier, A simple instance-based approach to multi-label classification using the Mallows model, in: *Proceedings of the Workshop on Learning from Multi-Label Data (MLD'09)*, 2009, pp. 28–38.
- [7] T. Cheng-Jung, L. Chien-I, Y. Wei-Pang, A discretization algorithm based on class-attribute contingency coefficient, *Information Sciences* 178 (2008) 714–731.
- [8] C. Chow, C. Liu, Approximating discrete probability distributions with dependence trees, *IEEE Transactions on Information Theory* 14 (1968) 462–467.
- [9] C. Chu, T. Liu, On the shortest arborescence of a directed graph, *Science Sinica* 14 (1968) 1396–1400.
- [10] G.F. Cooper, E.A. Herskovits, A Bayesian method for the induction of probabilistic networks from data, *Machine Learning* 9 (1992) 309–347.
- [11] A. Darwiche, Model-based diagnosis using causal networks, in: *International Joint Conference on Artificial Intelligence*, 1995, pp. 211–219.
- [12] H. Daumé III, D. Marcu, Learning as search optimization: approximate large margin methods for structured prediction, in: *Proceedings of the International Conference on Machine Learning*, 2005, pp. 169–176.
- [13] A.P. Dawid, Applications of a general propagation algorithm for probabilistic expert systems, *Statistics and Computing* 2 (1992) 25–36.
- [14] A. de Carvalho, A.A. Freitas, A tutorial on multi-label classification techniques, *Foundations of Computational Intelligence, Studies in Computational Intelligence*, vol. 5, Springer, 2009, pp. 177–195.
- [15] P.R. de Waal, L.C. van der Gaag, Inference and learning in multi-dimensional Bayesian network classifiers, *European Conference on Symbolic and Quantitative Approaches to Reasoning under Uncertainty, Lecture Notes in Artificial Intelligence*, vol. 4724, Springer, 2007, pp. 501–511.
- [16] K. Deb, S. Agrawal, A. Pratap, T. Meyarivan, A fast elitist non-dominated sorting genetic algorithm for multi-objective optimisation: NSGA-II, in: *Parallel Problem Solving from Nature (PPSN VI)*, *Lecture Notes in Computer Science*, 1917, 2000, pp. 849–858.
- [17] R. Dechter, Bucket elimination: a unifying framework for reasoning, *Artificial Intelligence* 113 (1–2) (1999) 41–85.
- [18] R. Dechter, I. Rish, A scheme for approximating probabilistic inference, in: *Proceedings of the Thirteenth Conference on Uncertainty in Artificial Intelligence*, 1997, pp. 132–141.
- [19] V. Delcroix, M.-A. Maalej, S. Piechowiak, Bayesian networks versus other probabilistic models for the multiple diagnosis of large devices, *International Journal on Artificial Intelligence Tools* 16 (3) (2007) 417–433.
- [20] K. Dembczyński, W. Waegeman, W. Cheng, E. Hüllermeier, On label dependence in multi-label classification, in: *Proceedings of the 2nd International Workshop on Learning from Multi-Label Data (MLD'10)*, 2010, pp. 5–12.
- [21] M.M. Drugan, M.A. Wiering, Feature selection for Bayesian network classifiers using the MDL-FS score, *International Journal of Approximate Reasoning* 51 (6) (2010) 695–717.
- [22] R.O. Duda, P. Hart, D. Stork, *Pattern Classification*, second ed., Wiley-Interscience, 2000.
- [23] A. Elisseeff, J. Weston, A kernel method for multi-labelled classification, in: T. Dietterich, S. Becker, Z. Ghahramani (Eds.), *Advances in Neural Information Processing Systems*, vol. 14, MIT Press, 2002, pp. 681–687.
- [24] N. Friedman, D. Geiger, M. Goldszmidt, Bayesian network classifiers, *Machine Learning* 29 (1997) 131–163.
- [25] S. García, F. Herrera, An extension on “Statistical comparisons of classifiers over multiple data sets” for all pairwise comparisons, *Journal of Machine Learning Research* 9 (2008) 2677–2694.
- [26] E.S. Gelsema, Abductive reasoning in Bayesian belief networks using a genetic algorithm, *Pattern Recognition Letters* 16 (8) (1995) 865–871.
- [27] S. Godbole, S. Sarawagi, Discriminative methods for multi-labeled classification, in: *Proceedings of the 8th Pacific-Asia Conference on Knowledge Discovery and Data Mining*, 2004, pp. 22–30.
- [28] D.-J. Guan, Generalized gray codes with applications, *Proceedings of the National Science Council of the Republic of China (A)* 22 (6) (1998) 842–848.
- [29] M. Henrion, Propagating uncertainty in Bayesian networks by probabilistic logic sampling, in: *Proceedings of the Second Annual Conference on Uncertainty in Artificial Intelligence*, 1986, pp. 317–324.
- [30] E. Hüllermeier, J. Fürnkranz, W. Cheng, K. Brinker, Label ranking by learning pairwise preferences, *Artificial Intelligence* 172 (16–17) (2008) 1897–1916.
- [31] F. Hutter, H.H. Hoos, T. Stützle, Efficient stochastic local search for MPE solving, in: *Proceedings of the Nineteenth International Joint Conference on Artificial Intelligence*, 2005, pp. 169–174.
- [32] P. Ibagüengoytia, L.E. Sucar, E. Morales, Probabilistic model-based diagnosis, in: *Proceedings of MICAL 2000, Lecture Notes in Artificial Intelligence*, vol. 1793, 2000, pp. 687–698.
- [33] K. Kask, R. Dechter, Mini-bucket heuristics for improved search, in: *Proceedings of the Fifteenth Conference on Uncertainty in Artificial Intelligence*, 1999, pp. 314–323.
- [34] K. Kask, R. Dechter, A general scheme for automatic generation of search heuristics from specification dependencies, *Artificial Intelligence* 129 (1–2) (2001) 91–131.
- [35] R. Kohavi, G. John, Wrappers for feature subset selection, *Artificial Intelligence* 97 (1–2) (1997) 273–324.
- [36] D. Koller, N. Friedman, *Probabilistic Graphical Models Principles and Techniques*, MIT Press, Cambridge, 2009.
- [37] P. Langley, S. Sage, Tractable average-case analysis of naïve Bayesian classifiers, in: *Proceedings of the 16th International Conference on Machine Learning*, 1999, pp. 220–228.
- [38] Z. Li, B. D'Ambrosio, An efficient approach for finding the MPE in belief networks, in: *Proceedings of the Ninth Annual Conference on Uncertainty in Artificial Intelligence*, 1993, pp. 342–349.
- [39] R. Marinescu, R. Dechter, AND/OR branch-and-bound search for combinatorial optimization in graphical models, *Artificial Intelligence* 173 (16–17) (2009) 1457–1491.
- [40] M. Minsky, Steps toward artificial intelligence, *Transactions on Institute of Radio Engineers* 49 (1961) 8–30.
- [41] C. Parker, Y. Altun, P. Tadepalli, Guest editorial: special issue on structured prediction, *Machine Learning* 77 (2009) 161–164.
- [42] J. Pearl, *Probabilistic Reasoning in Intelligent Systems: Networks of Plausible Inference*, Morgan Kaufmann Publishers, 1988.
- [43] Y. Peng, J.A. Reggia, A probabilistic causal model for diagnostic problem solving – Part I: Integrating symbolic causal inference with numeric probabilistic inference, *IEEE Transactions on Systems, Man, and Cybernetics* 17 (2) (1987) 146–162.
- [44] Y. Peng, J.A. Reggia, A probabilistic causal model for diagnostic problem solving. Part II: Diagnostic strategy, *IEEE Transactions on Systems, Man, and Cybernetics* 17 (3) (1987) 395–406.
- [45] A. Pérez, P. Larrañaga, I. Inza, Bayesian classifiers based on kernel density estimation: flexible classifiers, *International Journal of Approximate Reasoning* 50 (2) (2009) 341–362.
- [46] M. Qazi, G. Fung, S. Krishnan, R. Rosales, H. Steck, R. Rao, D. Poldermans, D. Chandrasekaran, Automated heart wall motion abnormality detection from ultrasound images using Bayesian networks, in: *International Joint Conference on Artificial Intelligence*, 2007, pp. 519–525.
- [47] J. Read, B. Pfahringer, G. Holmes, Multi-label classification using ensembles of pruned sets, *Proceedings of the Eighth IEEE International Conference on Data Mining (ICDM'08)*, IEEE Computer Society, 2008, pp. 995–1000.
- [48] G. Rebane, J. Pearl, The recovery of causal polytrees from statistical data, *Proceedings of the Third Annual Conference on Uncertainty in Artificial Intelligence (UAI-87)*, vol. 3, Elsevier, 1987, pp. 222–228.
- [49] S. Renooij, L.C. van der Gaag, Evidence and scenario sensitivities in naïve Bayesian classifiers, *International Journal of Approximate Reasoning* 49 (2) (2008) 398–416.
- [50] R.W. Robinson, Counting labeled acyclic digraphs, *New Directions in Graph Theory*, Academic Press, New York, 1973.
- [51] J.D. Rodríguez, J.A. Lozano, Multi-objective learning of multi-dimensional Bayesian classifiers, in: *Proceedings of the Eighth International Conference on Hybrid Intelligent Systems*, 2008, pp. 501–506.



- [52] C. Rojas-Guzmán, M.A. Kramer, GALGO: a genetic algorithm decision support tool for complex uncertain systems modeled with Bayesian belief networks, in: *Proceedings of the Ninth Annual Conference on Uncertainty in Artificial Intelligence*, 1993, pp. 368–375.
- [53] M. Sahami, Learning limited dependence Bayesian classifiers, in: *Proceedings of the 2nd International Conference on Knowledge Discovery and Data Mining*, 1996, pp. 335–338.
- [54] E. Santos, On the generation of alternative explanations with implications for belief revision, in: *Proceedings of the Seventh Annual Conference on Uncertainty in Artificial Intelligence*, 1991, pp. 339–347.
- [55] R.E. Schapire, Y. Singer, Boostexter: a boosting-based system for text categorization, *Machine Learning* 39 (2–3) (2000) 135–168.
- [56] S.E. Shimony, Finding MAPs for belief networks is NP-hard, *Artificial Intelligence* 68 (2) (1994) 399–410.
- [57] S.E. Shimony, E. Charniak, A new algorithm for finding MAP assignments to belief networks, in: *Proceedings of the Sixth Annual Conference on Uncertainty in Artificial Intelligence*, 1990, pp. 185–196.
- [58] M. Stone, Cross-validators choice and assessment of statistical predictions (with discussion), *Journal of the Royal Statistical Society B* 36 (1974) 111–147.
- [59] C. Sutton, A. McCallum, K. Rohanimanesh, Dynamic conditional random fields: Factorized probabilistic models for labelling and segmenting sequence data, *Journal of Machine Learning Research* 8 (2007) 693–723.
- [60] B. Taskar, C. Guestrin, D. Koller, Max-margin Markov networks, in: *Advances in Neural Information and Processing Systems*, vol. 16, MIT Press, 2004.
- [61] L. Tenenboim, L. Rokach, B. Shapira, Identification of label dependencies for multi-label classification, in: *Proceedings of the 2nd International Workshop on Learning from Multi-Label Data (MLD'10)*, 2010, pp. 53–60.
- [62] K. Trohidis, G. Tsoumakas, G. Kalliris, I. Vlahavas, Multi-label classification of music into emotions, in: *International Society for Music Information Retrieval Conference*, 2008, pp. 325–330.
- [63] I. Tsochantaridis, T. Joachims, T. Hofmann, Y. Altun, Large margin methods for structured and interdependent output variables, *Journal of Machine Learning Research* 6 (2005) 1453–1484.
- [64] G. Tsoumakas, A. Dimou, E. Spyromitros, V. Mezaris, I. Kompatsiaris, I. Vlahavas, Correlation-based pruning of stacked binary relevance models for multi-label learning, in: *Proceedings of the Workshop on Learning from Multi-Label Data (MLD'09)*, 2009, pp. 101–116.
- [65] G. Tsoumakas, I. Katakis, Multi-label classification: an overview, *International Journal of Data Warehousing and Mining* 3 (3) (2007) 1–13.
- [66] G. Tsoumakas, I. Katakis, I. Vlahavas, Effective and efficient multilabel classification in domains with large number of labels, in: *Proceedings of ECML/PKDD 2008 Workshop on Mining Multidimensional Data (MMD'08)*, 2008, pp. 30–44.
- [67] G. Tsoumakas, I. Katakis, I. Vlahavas, Mining multi-label data, *Data Mining and Knowledge Discovery Handbook*, Springer, 2010, pp. 667–686.
- [68] G. Tsoumakas, I. Katakis, I. Vlahavas, Random  $k$ -labelsets for multi-label classification, *IEEE Transactions on Knowledge and Data Engineering* (2011), in press.
- [69] N. Ueda, K. Saito, Parametric mixture models for multi-labeled text, in: *Advances in Neural Information Processing Systems*, vol. 15, 2002, pp. 721–728.
- [70] L. van der Gaag, P.R. de Waal, Multi-dimensional Bayesian network classifiers, in: *Third European Conference on Probabilistic Graphical Models*, 2006, pp. 107–114.
- [71] C. Vens, J. Struyf, L. Schietgat, S. Džeroski, H. Blockeel, Decision trees for hierarchical multi-label classification, *Machine Learning* 73 (2) (2008) 185–214.
- [72] M. Zhang, Z. Zhou, ML-KNN: a lazy learning approach to multi-label learning, *Pattern Recognition* 40 (7) (2007) 2038–2048.
- [73] M.L. Zhang, Z.H. Zhou, Multi-label neural networks with applications to functional genomics and text categorization, *IEEE Transactions on Knowledge and Data Engineering* 18 (10) (2006) 1338–1351.